

**16-/24-/48-Port 10/100/1000T 802.3at PoE +
2-/4-Port 1000X SFP Gigabit Ethernet Switch**

GSW-1820HP/GSW-2620HP/GSW-5240HP

User's Manual

Table of Contents

1. Package Contents	5
2. Product Features.....	6
3. Product Specifications	8
4. Hardware Introduction	11
4.1 Front Panel.....	11
4.2 LED Indicators.....	11
4.3 Multiple Functions of DIP Switch	13
4.4 Rear Panel	15
5. Hardware Installation	16
5.1 Rack Mounting.....	16
5.2 Installing the SFP Transceiver	18
Customer Support.....	19

Trademarks

Copyright © PLANET Technology Corp. 2025

Contents are subject to revision without prior notice.

PLANET is a registered trademark of PLANET Technology Corp.

All other trademarks belong to their respective owners.

Disclaimer

PLANET Technology does not warrant that the hardware will work properly in all environments and applications, and makes no warranty and representation, either implied or expressed, with respect to the quality, performance, merchantability, or fitness for a particular purpose.

PLANET has made every effort to ensure that this User's Manual is accurate; PLANET disclaims liability for any inaccuracies or omissions that may have occurred.

Information in this User's Manual is subject to change without notice and does not represent a commitment on the part of PLANET. PLANET assumes no responsibility for any inaccuracies that may be contained in this User's Manual. PLANET makes no commitment to update or keep current the information in this User's Manual, and reserves the right to make improvements to this User's Manual and/or to the products described in this User's Manual, at any time without notice.

If you find information in this manual incorrect, misleading, or incomplete, we would appreciate your comments and suggestions.

FCC Warning

This equipment has been tested and found to comply with the limits for a Class A digital device, pursuant to Part 15 of the FCC Rules. These limits are designed to provide reasonable protection against harmful interference when the equipment is operated in a commercial environment. This equipment generates, uses, and can radiate radio frequency energy and, if not installed and used in accordance with the Instruction manual, may cause harmful interference to radio communications. Operation of this equipment in a residential area is likely to cause harmful interference in which case the user will be required to correct the interference at his own expense.

CE Mark Warning

This device is compliant with Class A of CISPR 32. In a residential environment this equipment may cause radio interference.

Energy Saving Note of the Device

This power required device does not support Standby mode operation. For energy saving, please remove the power cable to disconnect the device from the power circuit. In view of saving the energy and reducing the unnecessary power consumption, it is strongly suggested to remove the power connection for the device if this device is not intended to be active.

WEEE Warning



To avoid the potential effects on the environment and human health as a result of the presence of hazardous substances in electrical and electronic equipment, end users of electrical and electronic equipment should understand the meaning of the crossed-out wheeled bin symbol. Do not dispose of WEEE as unsorted municipal waste and have to collect such WEEE separately.

Revision

PLANET 16-/24-/48-Port 10/100/1000T 802.3at PoE + 2-/4-Port 1000X SFP Gigabit Ethernet Switch

MODELS: GSW-1820HPv3, GSW-2620HPv5, GSW-5240HPv1







REVISION: 5.1 (JANUARY, 2025)

Part No: EM-GSW-1820HPv3_2620HPv5_v5240HPv1_v5.1 (Part No. 2351-AK5120-004)

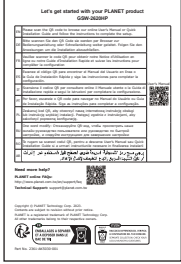
1. Package Contents

Thank you for purchasing PLANET 16-/24-/48-Port 10/100/1000T 802.3at PoE + 2-/4-Port 1000X SFP Gigabit Ethernet Switch, GSW-1820HP, GSW-2620HP or GSW-5240HP. **"802.3at PoE+ Switch"** mentioned in this manual refers to the GSW-1820HP, GSW-2620HP and GSW-5240HP.

Open the box of the 802.3at PoE+ Switch and carefully unpack it. The box should contain the following items:

The 802.3at PoE+ Switch		QR Code Sheet	Power Cord
			
Rack-mounting Brackets	Screws	Rubber Feet	SFP Dust Cap
			

Item \ Model Name	GSW-1820HPv3	GSW-2620HPv5	GSW-5240HPv1
The Industrial Managed Switch	1	1	1
QR Code Sheet x 1	1	1	1
Power Cord	1	1	1
Rack-mounting Brackets	2	2	2
Screws	8	8	8
SFP Dust Caps	2	2	4
Rubber Feet	4	4	4

If any of these pieces are missing or damaged, please contact your dealer immediately; if possible, retain the carton including the original packing material, and use them again to repack the product in case there is a need to return it to us for repair.

2. Product Features

➤ Physical Port

- **16-/24-/48-port 10/100/1000BASE-T** Gigabit RJ45 copper
- **2/4 1000BASE-X** SFP slots

➤ Power over Ethernet

- Complies with IEEE 802.3af/at Power over Ethernet end-span PSE
- Up to 16/24 ports of IEEE 802.3af/802.3at devices powered
- Supports PoE power up to 30 watts for each PoE port with up to 370W PoE budget.
- PD alive check function
- Each port supports 54V DC power to PoE powered device
- Auto detects powered device (PD)
- Circuit protection prevents power interference between ports
- Remote power feeding up to 100m in standard mode with 250m in extend mode

➤ Switching

- Hardware-based 10/100/1000Mbps auto-negotiation and auto MDI/MDI-X
- Supports IEEE 802.3x flow control for full-duplex mode and backpressure for half-duplex mode.
- Automatic address learning and address aging
- Supports Energy-Efficient Ethernet (EEE) function (IEEE 802.3az).

For GSW-5240HP Only:

- Integrates address look-up engine, supporting 16K auto-learning and auto-updating of MAC address table.
- 12K jumbo frame

For GSW-1820HP, GSW-2620HP Only:

- Integrates address look-up engine, supporting 8K absolute MAC addresses.
- 9K jumbo frame supports all speeds (10/100/1000Mbps).
- IEEE 802.1Q VLAN transparency
- Hardware-based DIP switch for **Standard**, **VLAN** and **Extend** mode selection;

- **VLAN mode:**

◆ **For GSW-1820HP:**

- Ports 1 to 14 will be isolated from each other.
- Ports 1 to 14 can only communicate with ports 15~16 (uplink ports) and SFP ports 17~18.

◆ **For GSW-2620HP:**

- Ports 1 to 22 will be isolated from each other.
- Ports 1 to 22 can only communicate with ports 23~24 (uplink ports) and SFP ports 25~26
- **Extend mode:** Ports 1 to 8 have a data rate of 10Mbps; the farthest transmission distance up to 250 meters and all ports can communicate with each other.
- The DIP switch can isolate ports to prevent broadcast storm and defend DHCP spoofing

➤ **Hardware**

- 19-inch rack-mount size, 1U height
- LED indicators for system power, per port PoE ready and PoE activity, speed, Link/Act
- Ethernet Link Energy-saving technology
 - Link down power saving
 - Intelligent scale power based on cable length

3. Product Specifications

Model	GSW-1820HP	GSW-2620HP	GSW-5240HP
Hardware Specifications			
10/100/1000BASE-T Copper Ports	16 auto-MDI/MDI-X ports	24 auto-MDI/MDI-X ports	48 auto-MDI/MDI-X ports
802.3af/802.3at PoE+ Injector Ports	16	24	48
1000BASE-X SFP Ports	2	2	4
DIP Switch	Selectable operation mode <ul style="list-style-type: none"> ■ Standard ■ VLAN ■ Extend 		-
Dimensions (W x D x H)	441 x 207 x 44 mm (1U height)		440 x 330 x 44.5 mm (1U height)
Enclosure	Metal		
Weight	2.35kg	2.44kg	4.9kg
Power Requirements	100~240V AC, 50/60Hz, 5A max.	100~240V AC, 50/60Hz, 5A max.	100~240V AC, 50/60Hz, 5.5A max.
Power Consumption/Dissipation	Max. 262 watts/893 BTU	Max. 272 watts/928 BTU	Max. 420 watts/1432 BTU
Thermal Fan	2	2	4
LED	System: Power (Green) PoE Usage 80% (Green) 10/100/1000T RJ45 Interfaces (Ports 1 to 16) 10/100/1000 LNK/ACT (Green), PoE-in-Use (Amber) 1000X SFP Interfaces (Ports 17 to 18) 1000 LNK/ACT (Green)	System: Power (Green) PoE Usage 80% (Green) 10/100/1000T RJ45 Interfaces (Ports 1 to 24) 10/100/1000 LNK/ACT (Green), PoE-in-Use (Amber) 1000X SFP Interfaces (Ports 25 to 26) 1000 LNK/ACT (Green)	System: Power (Green) 10/100/1000T RJ45 Interfaces (Ports 1 to 48) 10/100/1000 LNK/ACT (Green), PoE-in-Use (Amber) 1000X SFP Interfaces (Ports 49 to 52) 1000 LNK/ACT (Green)

Switching Specifications			
Switch Architecture	Store-and-Forward		
Switch Fabric	36Gbps/ non-blocking	52Gbps/ non-blocking	104Gbps/ non-blocking
Switch Throughput@64bytes	26.8Mpps	38.7Mpps	77.3Mpps
MAC Address Table	8K entries		16K entries
Jumbo Frame	9216 bytes		12K bytes
Flow Control	IEEE 802.3x pause frame for full duplex; back pressure for half duplex		
Power over Ethernet			
PoE Standard	IEEE 802.3at Power over Ethernet Plus/PSE		
PoE Power Supply Type	End-span: 1/2 (+), 3/6 (-)		
PoE Power Output	Per port 54V DC, 300mA. max. 15.4 watts (IEEE 802.3af) Per port 54V DC, 600mA. max. 30 watts (IEEE 802.3at)		
PD Alive Check	Yes		
PoE Power Budget	250 watts	250 watts	370 watts
Number of PDs, 7 watts	16	24	48
Number of PDs, 15.4 watts	16	16	24
Number of PDs, 30 watts	8	8	12

Standards Conformance	
Regulatory Compliance	FCC Part 15 Class A, CE
Standards Compliance	IEEE 802.3 10BASE-T IEEE 802.3u 100BASE-TX IEEE 802.3ab Gigabit 1000BASE-T IEEE 802.3z Gigabit SX/LX IEEE 802.3x flow control and back pressure IEEE 802.3af Power over Ethernet IEEE 802.3at Power over Ethernet Plus IEEE 802.3az Energy-Efficient Ethernet
Environment	
Operating	Temperature: 0 ~ 50 degrees C Relative Humidity: 5 ~ 95% (non-condensing)
Storage	Temperature: -10 ~ 70 degrees C Relative Humidity: 5 ~ 95% (non-condensing)

4. Hardware Introduction

4.1 Front Panel

The front panel of the 802.3at PoE+ Switch consists of 16/24 auto-sensing 10/100/1000Mbps Ethernet RJ45 ports. The LED Indicators are also located on the front panel of the 802.3at PoE+ Switch.

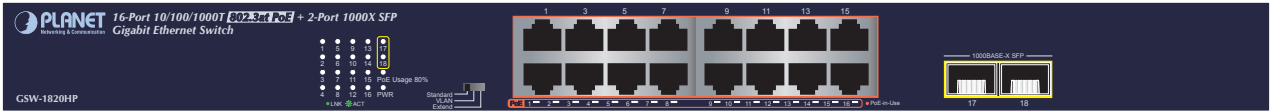

Figure 4-1: GSW-1820HP Switch Front Panel

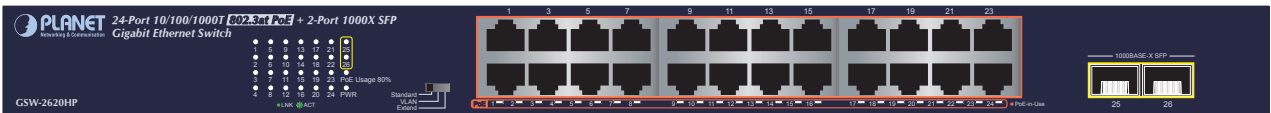

Figure 4-2: GSW-2620HP Switch Front Panel

4.2 LED Indicators

■ System

LED	Color	Function
PWR	Green	Lights to indicate the Switch has power.
PoE Usage 80%	Green	Lights to indicate the system has 80% PoE power usage (About 200W).

■ Per 10/100/1000BASE-T Port

LED	Color	Function	
LNK/ACT	Green	Lights	To indicate the link through that port is successfully established at 10/100/1000Mbps.
		Blinks	To indicate that the switch is actively sending or receiving data over that port.
PoE-in-Use	Amber	Lights	To indicate the port is providing DC in-line power.
		Off	To indicate the connected device is not a PoE powered device (PD)

■ Per 1000BASE-X SFP Interface

LED	Color	Function	
LNK/ACT	Green	Lights	To indicate the link through that port is successfully established at 1000Mbps.
		Blinks	To indicate that the switch is actively sending or receiving data over that port.
		Off	To indicate that the port is link down.

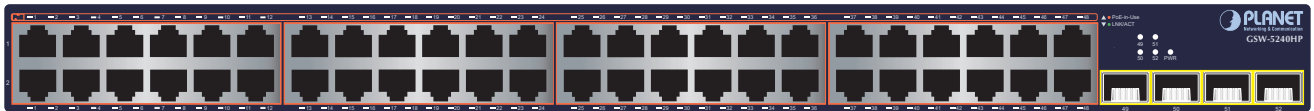

Figure 4-3: GSW-5240HP Switch Front Panel

LED Indicators

■ System

LED	Color	Function
PWR	Green	Lights to indicate that the Switch has power.
	Off	Power is off.



■ Interfaces

LED	Color	Function	
LNK/ACT	Green	Lights	Indicating the port is running and the connection is successfully established.
		Blinks	Indicating that the switch is actively sending or receiving data over that port.
PoE-in-Use	Amber	Lights	PD is connected and PoE power supply is normal.
		Off	PD is not connected or PoE power supply is not provided.

4.3 Multiple Functions of DIP Switch

For GSW-1820HP and GSW-2620HP only

The front panel of the 802.3at PoE+ Switch provides one DIP switch for **Standard**, **VLAN** and **Extend** mode selections. The detailed descriptions are shown in the following table.

DIP Switch Mode	Function
 <p>Standard VLAN Extend</p>	<p>This mode makes the 802.3at PoE+ Switch operate as a general switch and all PoE ports operate at 10/100/1000Mbps auto-negotiation. All ports can communicate with one another.</p>
 <p>Standard VLAN Extend</p>	<p>This mode makes the 802.3at PoE+ Switch operate as a VLAN isolation switch and</p> <p>For GSW-1820HP:</p> <ol style="list-style-type: none">1. Ports 1 to 14 will be isolated from each other.2. Ports 1 to 14 can only communicate with ports 15~16 (uplink ports) and SFP ports 17~18. <p>For GSW-2620HP:</p> <ol style="list-style-type: none">1. Ports 1 to 22 will be isolated from each other.2. Ports 1 to 22 can only communicate with ports 23~24 (uplink ports) and SFP ports 25~26.
 <p>Standard VLAN Extend</p>	<p>This mode makes the 802.3at PoE+ Switch operate as a Long Reach PoE switch and</p> <ol style="list-style-type: none">1. Ports 1 to 8 support the farthest transmission distance of up to 250 meters2. Ports 1 to 8 have a data rate of 10Mbps3. All ports can communicate with one another.



Note

Please adjust the DIP switch before powering on the 802.3at PoE+ Switch.

Standard Mode (default)

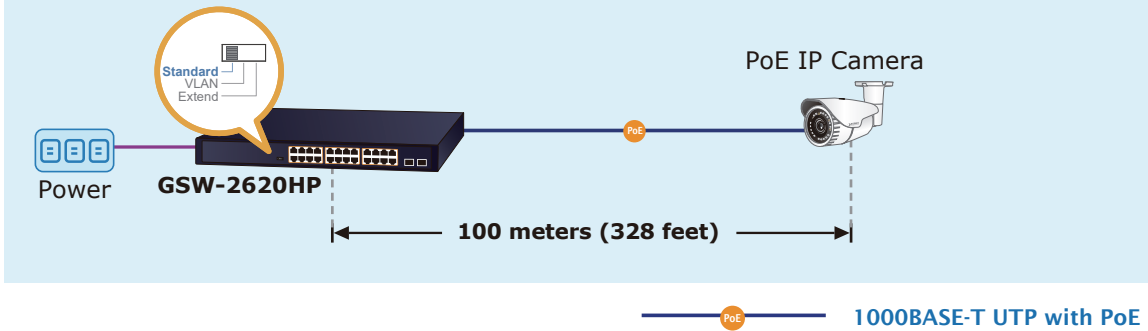

VLAN Isolation Mode

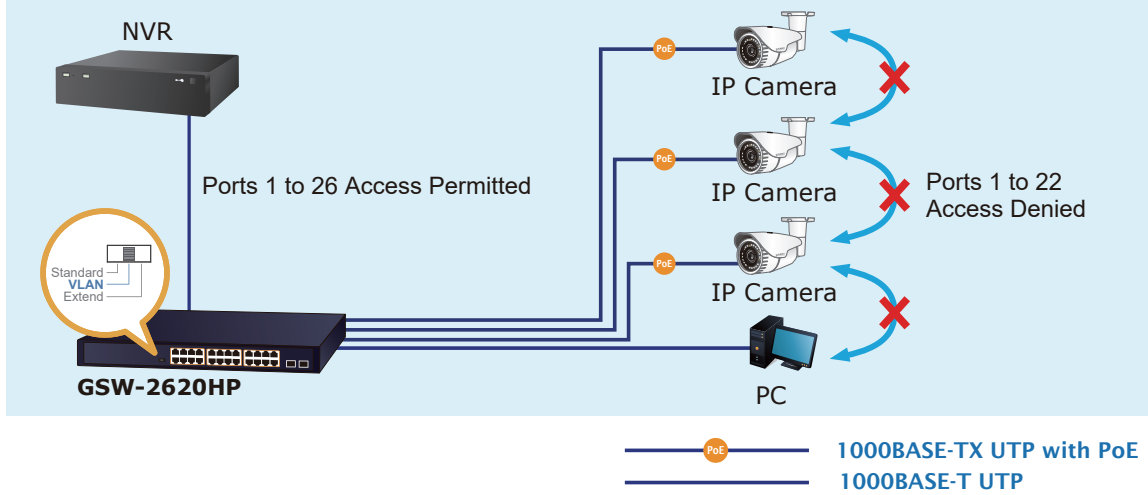

Extend Mode

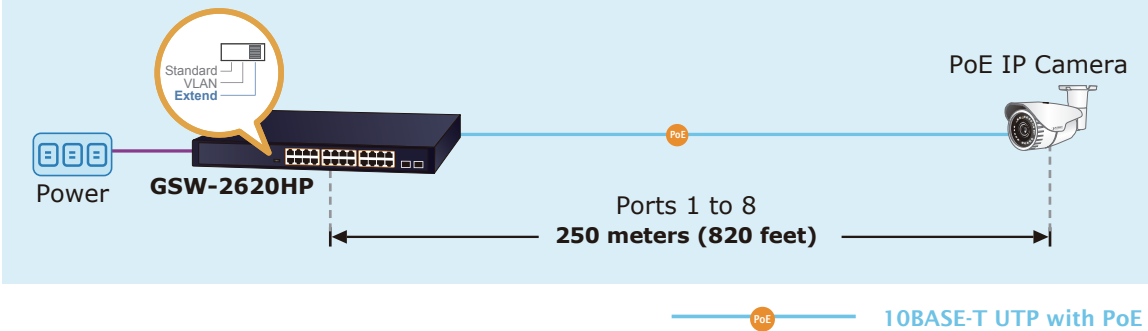

4.4 Rear Panel

The rear panel of the 802.3at PoE+ Switch indicates an AC power socket, which accepts input power from 100 to 240V AC, 50-60Hz, 5A.



Figure 4-4: GSW-1820HP/GSW-2620HP Switch Rear Panel



Figure 4-5: GSW-5240HP Switch Rear Panel

■ AC Power Receptacle



Power Notice

The device is a power-required device, which means it will not work till it is powered. If your networks should be active all the time, please consider using UPS (Uninterrupted Power Supply) for your device. It will prevent you from network data loss or network downtime.



Power Notice

In some areas, installing a surge suppression device may also help to protect your 802.3at PoE+ Switch from being damaged by unregulated surge or current to the 802.3at PoE+ Switch or the power adapter.

5. Hardware Installation

5.1 Rack Mounting

To install the 802.3at PoE+ Switch in a 19-inch standard rack, follow the instructions described below.

Step 1: Place your 802.3at PoE+ Switch on a hard flat surface, with the front panel positioned towards your front side.

Step 2: Attach a rack-mount bracket to each side of the 802.3at PoE+ Switch with supplied screws attached to the package. Figure 5-1 shows how to attach brackets to one side of the 802.3at PoE+ Switch.

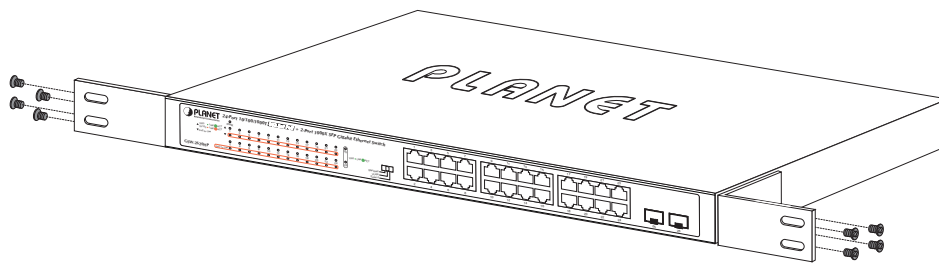

Figure 5-1: Attaching the Brackets to the 802.3at PoE+ Switch.



Caution

You must use the screws supplied with the mounting brackets. Damage caused to the parts by using incorrect screws would invalidate the warranty.

Step 3: Secure the brackets tightly.

Step 4: Follow the same steps to attach the second bracket to the opposite side.

Step 5: After the brackets are attached to the 802.3at PoE+ Switch, use suitable screws to securely attach the brackets to the rack, as shown in Figure 5-2.

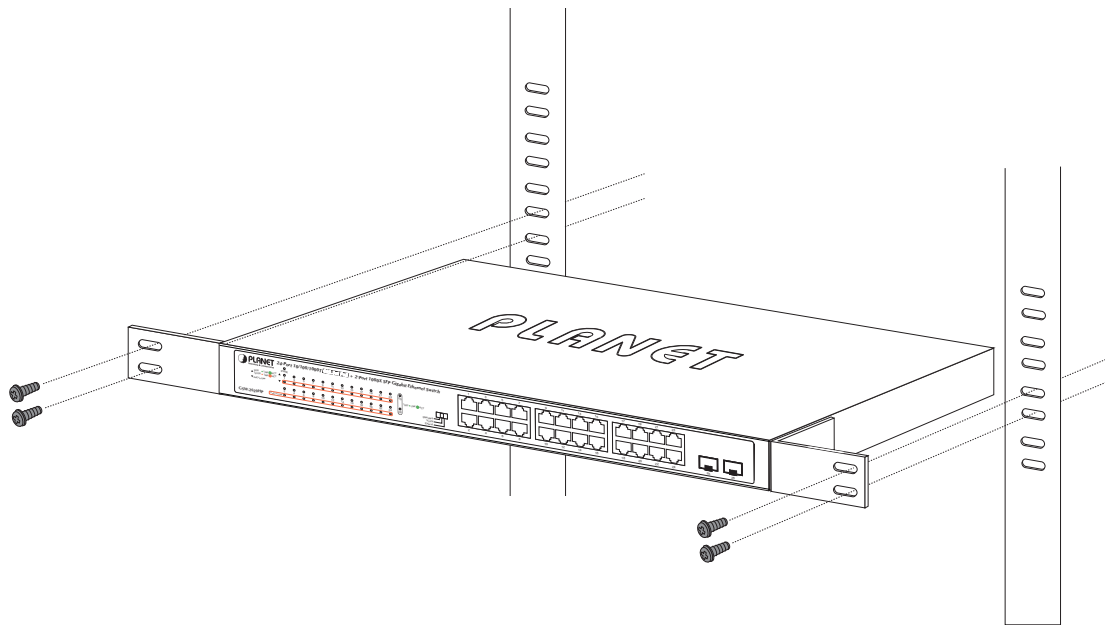

Figure 5-2: Mounting the 802.3at PoE+ Switch in a Rack

Step 6: Connect your 802.3at PoE+ Switch to 802.3af/802.3at complied PDs and other network devices.

- A. Connect one end of a standard network cable to the 10/100/1000BASE-T RJ45 ports on the front panel of the 802.3at PoE+ Switch.
- B. Connect the other end of the cable to the network devices such as printer servers, workstations or routers, etc.

Step 7: Supply power to the 802.3at PoE+ Switch.

- A. Connect one end of the power cable to the 802.3at PoE+ Switch.
- B. Connect the power plug of the power cable to a standard wall outlet.

When the 802.3at PoE+ Switch receives power, the power LED should remain solid Green.

5.2 Installing the SFP Transceiver

The sections describe how to insert an SFP transceiver into an SFP slot of the 802.3at PoE+ Switch.

The SFP transceivers are hot-pluggable and hot-swappable. You can plug in and out the transceiver to/from any SFP port without having to power down the 802.3at PoE+ Switch, as Figure 5-3 shows.

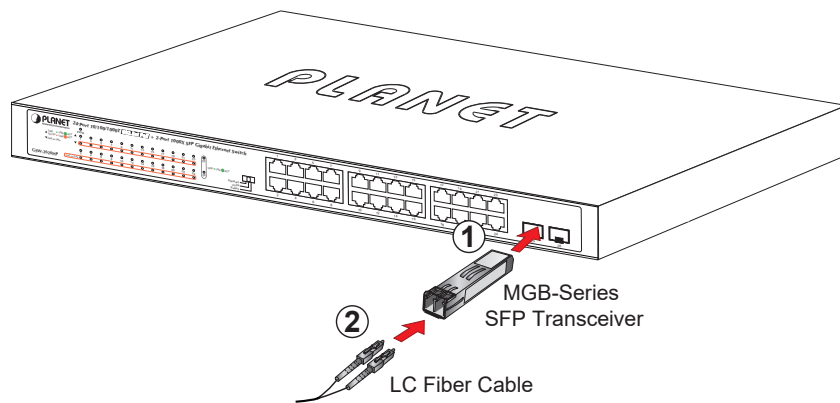

Figure 5-3: Plug In the SFP Transceiver

■ Approved PLANET SFP Transceivers

PLANET 802.3at PoE+ Switch supports both single mode and multi-mode SFP transceivers. The website link of approved PLANET SFP transceivers is shown below:

<https://www.planet.com.tw/en/product/mgb-series-transceiver?c1=lan-switches&c2=switch-accessories&c3=gigabit-transceiver>



Caution

It is recommended to use PLANET SFP on the 802.3at PoE+ Switch. If you insert an SFP transceiver that is not supported, the 802.3at PoE+ Switch will not recognize it.

1. Before we connect the 802.3at PoE+ Switch to the other network device, we have to make sure both sides of the SFP transceivers are with the same media type, for example, 1000BASE-SX to 1000BASE-SX; 1000BASE-LX to 1000BASE-LX.
2. Check whether the fiber-optic cable type matches with the SFP transceiver requirement.
 - To connect to 1000BASE-SX SFP transceiver, please use the multi-mode fiber cable with one side being the male duplex LC connector type.
 - To connect to 1000BASE-LX SFP transceiver, please use the single-mode fiber cable with one side being the male duplex LC connector type.

Customer Support

Thank you for purchasing PLANET products. You can browse our online FAQ resource on PLANET Web site first to check if it could solve your issue. If you need more support information, please contact PLANET support team.

PLANET online FAQs:

<https://www.planet.com.tw/en/support/faq>

Support team mail address

support@planet.com.tw

Copyright © PLANET Technology Corp. 2025

Contents are subject to revision without prior notice.

PLANET is a registered trademark of PLANET Technology Corp.

All other trademarks belong to their respective owners.