

# User's Manual



## High Definition Color PoE IP Phone

▶ VIP-1120PT



## **Copyright**

Copyright © 2016 by PLANET Technology Corp. All rights reserved. No part of this publication may be reproduced, transmitted, transcribed, stored in a retrieval system, or translated into any language or computer language, in any form or by any means, electronic, mechanical, magnetic, optical, chemical, manual or otherwise, without the prior written permission of PLANET.

PLANET makes no representations or warranties, either expressed or implied, with respect to the contents hereof and specifically disclaims any warranties, merchantability or fitness for any particular purpose. Any software described in this manual is sold or licensed "as it is". Should the programs prove defective following their purchase, the buyer (and not PLANET, its distributor, or its dealer) assumes the entire cost of all necessary servicing, repair, and any incidental or consequential damages resulting from any defect in the software. Further, PLANET reserves the right to revise this publication and to make changes from time to time in the contents hereof without obligation to notify any person of such revision or changes.

All brand and product names mentioned in this manual are trademarks and/or registered trademarks of their respective holders.

## **Federal Communication Commission Interference Statement**

This equipment has been tested and found to comply with the limits for a Class B digital device, pursuant to Part 15 of FCC Rules. These limits are designed to provide reasonable protection against harmful interference in a residential installation. This equipment generates, uses, and can radiate radio frequency energy and, if not installed and used in accordance with the instructions, may cause harmful interference to radio communications. However, there is no guarantee that interference will not occur in a particular installation. If this equipment does cause harmful interference to radio or television reception, which can be determined by turning the equipment off and on, the user is encouraged to try to correct the interference by one or more of the following measures:

1. Reorient or relocate the receiving antenna.
2. Increase the separation between the equipment and receiver.
3. Connect the equipment into an outlet on a circuit different from that to which the receiver is connected.
4. Consult the dealer or an experienced radio technician for help.

## **FCC Caution**

To assure continued compliance, for example, use only shielded interface cables when connecting to computer or peripheral devices. Any changes or modifications not expressly approved by the party responsible for compliance could void the user's authority to operate the equipment.

This device complies with Part 15 of the FCC Rules. Operation is subject to the following two conditions: (1) This device may not cause harmful interference, and (2) this device must accept any interference received, including interference that may cause undesired operation.

### **Federal Communication Commission (FCC) Radiation Exposure Statement**

This equipment complies with FCC radiation exposure set forth for an uncontrolled environment. In order to avoid the possibility of exceeding the FCC radio frequency exposure limits, human proximity to the antenna shall not be less than 20 cm (8 inches) during normal operation.

### **Safety**

This equipment is designed with the utmost care for the safety of those who install and use it. However, special attention must be paid to the dangers of electric shock and static electricity when working with electrical equipment. All guidelines of this and of the computer manufacture must therefore be allowed at all times to ensure the safe use of the equipment.

### **CE Mark Warning**

This is a Class B product. In a domestic environment, this product may cause radio interference, in which case the user may be required to take adequate measures.

### **WEEE Regulation**



To avoid the potential effects on the environment and human health as a result of the presence of hazardous substances in electrical and electronic equipment, end users of electrical and electronic equipment should understand the meaning of the crossed-out wheeled bin symbol. Do not dispose of WEEE as unsorted municipal waste; they should be collected separately.

### **Revision**

User's Manual of PLANET High Definition Color PoE IP Phone

Model: VIP-1120PT

Rev: 1.00 (September, 2016)

Part No. EM-VIP-1120PT\_v1.0

# Table of Contents

<b>Chapter 1. Product Introduction .....</b>	<b>10</b>
1.1 Package Contents.....	10
1.2 Overview .....	10
1.3 Features .....	13
1.4 Specifications.....	15
<b>Chapter 2. Hardware Interface &amp; Installation.....</b>	<b>18</b>
2.1 Physical Descriptions.....	18
2.2 Using Handset/Hands-free Speaker/Headphone .....	20
2.3 Desktop and Wall-mount Installation .....	22
<b>Chapter 3. Introduction to the Phone User Interface.....</b>	<b>23</b>
3.1 Screen User Interface .....	23
3.2 Web Portal .....	24
<b>Chapter 4. IP Phone Setting Up .....</b>	<b>26</b>
4.1 Network Configuration .....	26
4.2 Line Configurations .....	27
<b>Chapter 5. Using the Phone.....</b>	<b>36</b>
5.1 Making Phone Calls .....	36
5.2 Make/Receive Second Call.....	40
5.3 Join/Split Two Calls (3-way Local Conference) .....	42
5.4 Call Transfer.....	42
5.5 Using Phonebook.....	43
5.6 Add/Edit/Delete Contact.....	44
5.7 Add/Edit/Delete Group .....	45
5.8 Browse and Add/Remove Contacts in Group.....	46
5.9 Using Cloud Phonebook .....	47
5.10 Open Cloud Phonebook.....	48
5.11 Call Logs .....	49
5.12 Voice Message .....	50
5.13 Do-Not-Disturb .....	52
5.14 Auto-Answering.....	53
5.15 Call Forward.....	54
<b>Chapter 6. Phone Settings.....</b>	<b>57</b>
6.1 Adjust Audio Volume.....	57

6.2	Set Ring Tone Volume and Type.....	57
6.3	Adjust LCD Contrast .....	57
6.4	Set Device Time/Date .....	58
6.5	Set Device Language.....	59
6.6	Reboot the Device .....	59
6.7	Reset to Factory Default .....	59
<b>Chapter 7.</b>	<b>Web Portal .....</b>	<b>60</b>
7.1	Web Portal Authentication .....	60
7.2	Web Call.....	60
7.3	SYSTEM (Information).....	62
7.4	SYSTEM (Account).....	62
7.5	SYSTEM (Configurations).....	63
7.6	SYSTEM (Upgrade) .....	63
7.7	SYSTEM (Auto Provision).....	63
7.8	SYSTEM (Tools) .....	63
7.9	NETWORK (Basic) .....	63
7.10	NETWORK (Advanced) .....	64
7.11	NETWORK (VPN).....	64
7.12	LINES (SIP).....	64
7.13	LINES (Dial Peer) .....	68
7.14	LINES (Dial Plan).....	73
7.15	LINES (Global Settings).....	74
7.16	PHONE (Features).....	75
7.17	PHONE (Audio).....	77
7.18	PHONE (MCAST) .....	79
7.19	PHONE (Time/Date) .....	79
7.20	PHONE (Advanced).....	80
7.21	PHONEBOOK (Contacts) .....	80
7.22	PHONEBOOK (Cloud Phonebook).....	81
7.23	PHONEBOOK (Blacklist) .....	82
7.24	PHONEBOOK (Advanced) .....	82
7.25	CALL LOGS .....	82
7.26	FUNCTION KEY .....	83
7.27	FUNCTION KEY (Softkey).....	84
<b>Chapter 8.</b>	<b>Advanced Features.....</b>	<b>85</b>
8.1	VPN.....	85
8.2	L2TP.....	85

8.3	OpenVPN .....	86
<b>Chapter 9.</b>	<b>Troubleshooting.....</b>	<b>87</b>
9.1	Get Device System Information .....	87
9.2	Upgrade to the latest software .....	87
9.3	Reboot Device .....	87
9.4	Reset Device to Factory Default .....	87
9.5	Network Packets Capture .....	88
9.6	Common Trouble Cases .....	88
	<b><i>Appendix I - Icon Illustration .....</i></b>	<b>90</b>
	<b><i>Appendix II - Text Input from Keypad.....</i></b>	<b>92</b>
	<b><i>Appendix III - LED Definition .....</i></b>	<b>94</b>

# Figures

Figure 1 - Keypad.....	18
Figure 2 - Connecting to the Device .....	20
Figure 3 - Desktop Installation .....	22
Figure 4 - Wall-mount Installation .....	22
Figure 5 - Screen Layout/Default Standby Screen .....	23
Figure 6 - Vertical Scroll Bar .....	24
Figure 7 - Check the Device's IP Address .....	24
Figure 9 - Configure SIP Proxy Server Address .....	27
Figure 10 - Configure SIP Proxy Server Port.....	28
Figure 11 - Configure SIP Username.....	28
Figure 12 - Configure Authentication Name .....	28
Figure 13 - Configure SIP Authentication Password .....	29
Figure 14 - Configure Display Name.....	29
Figure 15 - Enable/Disable Outbound Proxy .....	29
Figure 16 - Enable/Disable SIP Line.....	30
Figure 17 - Configure Advanced Line Options.....	30
Figure 18 - Configure SIP Realm/Domain .....	31
Figure 19 - Configure Unregistered Dial .....	31
Figure 20 - Enable/Disable Anonymous .....	31
Figure 21 - Configure DTMF Mode .....	32
Figure 22 - Enable/Disable STUN.....	32
Figure 23 - Configure Local Port.....	32
Figure 24 - configure Ring Type .....	33
Figure 25 - Configure MWI Number.....	33
Figure 26 - Configure Pickup Number .....	33
Figure 27 - Configure Park Number.....	34
Figure 28 - Configure Join Call Number .....	34
Figure 30 - Enable/Disable Feature Sync.....	35
Figure 31 - Enable/Disable SCA .....	35
Figure 32 - Default Line .....	36
Figure 33 - Dialing a Number before Audio Channel Opened.....	37
Figure 34 - Dial a Number after Audio Channel Opened.....	37
Figure 35 - Calling Remote Party.....	38
Figure 36 - Incoming Call Screen .....	38
Figure 37 - Talking Mode Screen.....	39

Figure 38 - Call Holding Screen.....	40
Figure 40 - Dual Calls .....	41
Figure 41 - Conference Call.....	42
Figure 42 - Phonebook Screen .....	43
Figure 43 - Phonebook is Empty.....	44
Figure 44 - Browsing Phonebook.....	44
Figure 45 - Add New Contact.....	45
Figure 46 - Group List .....	46
Figure 47 - Browsing Contacts in a Group.....	46
Figure 48 - Add/Remove Contacts in a Group.....	47
Figure 49 - Cloud Phonebook List .....	48
Figure 50 - Downloading Cloud Phonebook .....	48
Figure 51 - Browsing Contacts in Cloud Phonebook .....	49
Figure 52 - Call Logs.....	49
Figure 53 - Filter Call Log Type .....	50
Figure 54 - New Voice Message Notification .....	51
Figure 55 - Voice Message Screen.....	51
Figure 56 - Configure the Voice Message Number .....	52
Figure 57 - DND Enabled on All Lines .....	52
Figure 58 - Configure DND on Line .....	53
Figure 60 - Auto-answering Enabled on Line1 .....	54
Figure 61 - Select Line for Call Forward Configuration.....	55
Figure 62 - Select Call Forward Type .....	55
Figure 63 - Activate Call Forward and configure Call Forward Number .....	56
Figure 64 - Set Delay Time for Call Forward on No Answer.....	56
Figure 65 - Web Call Controls.....	61
Figure 66 - Web Call, Entering Number and Select Line.....	61
Figure 70 - Add Suffixes Configuration .....	72
Figure 71 - Deletion Configuration .....	73
Figure 72 - Dial Plan Configuration.....	73
Figure 73 - Softkey Configuration .....	84



# Tables

Table 1 - Specifications.....	15
Table 2 - Keypad Descriptions.....	19
Table 3 - Interface Descriptions.....	21
Table 4 - Time Settings Parameters.....	58
Table 5 - Line Configuration on Web.....	64
Table 6 - Global Settings for Lines on Web.....	74
Table 7 - Common Phone Feature Settings on Web.....	75
Table 8 - Audio Settings on Web.....	77
Table 9 - MCAST Parameters on Web.....	79
Table 10 - Time/Date Setting Parameters on Web.....	79
Table 11 - DSS Key Setting Parameters on Web.....	83
Table 12 - Trouble Cases.....	88
Table 13 - Keypad Icons.....	90
Table 14 - Status Prompt and Notification Icons.....	90
Table 15 - Look-up Table of Characters.....	92
Table 16 - DSS KEY LED State.....	94


# Chapter 1. Product Introduction

## 1.1 Package Contents

Please read the following safety notices before installing or using this unit. They are crucial for the safe and reliable operation of the device.

The package should contain the following items:

- SIP IP Phone Unit x 1
- Quick Installation Guide x 1
- RJ45 Cable x 1
- Stand x 1

 Note	<ol style="list-style-type: none"><li>1. If any of the above items are missing, please contact your dealer immediately.</li><li>2. Using the power supply that is not the one included in the camera packet will cause damage and void the warranty for this product.</li></ol>
--	---

## 1.2 Overview

### Intuitive Design Brings Quality Communication

PLANET VIP-1120PT is a two-line SIP desktop phone with color display that brings lifelike richness and voice quality to phone calls. The VIP-1120PT is a reliable communication device as it features ease of use, versatility, high-quality design and superb audio performance. Besides, its full duplex speakerphone system with HD voice can definitely make communication between two or more business parties crystal clear with no interference noise in the background as it supports the G.722 wideband codec.



### **IP Phone with Color Display**

As the VIP-1120PT is an IP phone, it allows you to make calls from any location easily as long as it is online. Its 2.4-inch TFT color display with a resolution of 320 x 240 pixels offers a clear depiction of caller's information. It complies with IEEE 802.3af PoE interface for flexible deployment and supports superior audio quality delivered by the advanced speaker and microphone system, and the digital signal processor (DSP).



### **Compliant with SIP 2.0**

SIP phones continue to gain popularity among businesses as the preferred protocol for enhancing communication across IP networks. The VIP-1120PT supports Session Initiation Protocol 2.0 (RFC 3261) for easy integration with general voice over IP system. The VIP-1120PT is able to broadly interoperate with equipment provided by VoIP infrastructure providers, thus enabling them to provide their customers with better voice over IP services.



## 1.3 Features

### ➤ **Highlights**

- 2.4-inch color LCD monitor
- 2-line key with color LED
- SIP identities
- Wideband G.722 HD audio
- Power over Ethernet (PoE) compliant
- QoS, TR069, auto-provisioning and multi-language

### ➤ **Advantageous Applications**

- Supports SIP 2.0 (RFC3261)
- Inband, SIP info, RFC 2833 DTMF relay
- Soft keys and function keys programmable
- Echo cancellation: Supports G.168, and a maximum filter length of 96ms in hands-free mode
- Supports voice gain setting, voice activity detection (VAD) and comfort noise generation (CNG)
- Full duplex hands-free speakerphone
- Hands-free headset ringing choice
- Voice codec setting for each SIP line

### ➤ **SIP Applications**

- Call forward and transfer (blind/attended)
- Call holding and waiting
- 3-way conferencing
- Paging and intercom
- Call park, call pickup and join call
- Redial and click to dial
- Secondary dialing automatically
- Incoming calls, outgoing calls and missed calls (Each supports 300 records)
- SMS and speed dial
- Phonebook up to 500 records

### ➤ **Call Control Features**

- Flexible dial map, hotline and empty calling no. for rejected service
- Black list for rejected authenticated calls

- White list and call limit
- Do not disturb (DND)
- Caller ID display
- Dial without registration

➤ **Network Features**

- PPPoE/DHCP client
- 802.1 VLAN (voice VLAN/data VLAN)
- VPN (L2TP) and openVPN
- Quality of Service

➤ **Maintenance and Management**

- Integrated web server provides web-based administration and configuration
- Telephone keypad configuration via display menu/navigation
- Automated provisioning and upgrade via HTTPS, HTTP, TFTP
- User authentication for configuration pages
- SNTP time synchronization
- TR069

## 1.4 Specifications

**Table 1 – Specifications**

<b>Product</b>	VIP-1120PT
<b>Hardware</b>	
<b>Lines (Direct Numbers)</b>	2 SIP Lines
<b>Display</b>	LCD x 1: 2.4-inch (320 x 240) color LCD
<b>Feature Keys</b>	Keypad: 32 keys, including <ul style="list-style-type: none"> <li>● 4 soft-keys</li> <li>● 12 standard phone digit keys</li> <li>● 5 navigation keys</li> <li>● 2-line key with tri-color LED</li> <li>● 5 function keys</li> <li>● 3 volume control keys -- Up, Down, Mute (microphone)</li> <li>● 1 hands-free feature</li> </ul>
<b>Network Interfaces</b>	RJ45 Ethernet jacket x 2: <ul style="list-style-type: none"> <li>● Network x 1 (802.3af PoE Class 1 enabled)</li> <li>● PC x 1 (Bridged Network)</li> </ul>
<b>Connectors</b>	HD hands-free speaker (0 ~ 7KHz) x 1 HD hands-free microphone (0 ~ 7KHz) x 1 HD handset (RJ9) x 1
<b>Power Requirements</b>	IEEE 802.3af 5V 600mA
<b>Weight</b>	620g
<b>Dimensions (W x D x H)</b>	196 x 164 x 60 mm
<b>Protocols and Standard</b>	
<b>Protocols</b>	<ul style="list-style-type: none"> <li>■ SIP2.0 over UDP/TCP/TLS</li> <li>■ RTP/RTCP/SRTP</li> <li>■ STUN</li> <li>■ DHCP</li> <li>■ PPPoE</li> <li>■ 802.1x</li> <li>■ L2TP (basic unencryption)</li> <li>■ OpenVPN</li> </ul>

	<ul style="list-style-type: none"> <li>■ SNTP</li> <li>■ FTP/TFTP</li> <li>■ HTTP/HTTPS</li> <li>■ TR069</li> </ul>
<b>Request for Comments (RFCs)</b>	354, 1321, 1350, 1769, 1889, 1890, 2131, 2132, 2616, 2617, 2661, 2833, 2976, 3261, 3262, 3263, 3264, 3265, 3268, 3311, 3489, 3711, 4346, 4566, 5630, 5865
<b>Networking</b>	
<b>Networking</b>	Physical: 10/100Mbps Ethernet, dual bridged port for PC bypass IP Configuration: Static, DHCP, PPPoE Network Access Control: 802.1x VPN: L2TP (basic unencryption), OpenVPN VLAN QoS
<b>Deployment &amp; Maintenance</b>	Auto-provisioning via FTP/TFTP/HTTP/HTTPS/DHCP/OPT66/SIP PNP/TR069 Web management portal Web-based packet dump Configuration backup/restore Auto/Manual online software upgrade Syslog
<b>Features</b>	
<b>Call Features</b>	<ul style="list-style-type: none"> <li>■ Call out, answer, reject</li> <li>■ Mute/unmute (microphone)</li> <li>■ Call hold, resume</li> <li>■ Call waiting</li> <li>■ Intercom</li> <li>■ Caller ID display</li> <li>■ Call forwarding (always/busy/no answer)</li> <li>■ Call transfer (attended/unattended)</li> <li>■ Call parking, pick-up (depending on server)</li> <li>■ Redial</li> <li>■ Do-not-disturb (per line/per phone)</li> <li>■ Auto-answering (per line)</li> <li>■ Voice message (on server)</li> <li>■ Local 3-way conferencing</li> </ul>



	<ul style="list-style-type: none"> <li>■ Hot line</li> </ul>
<b>Phone Features</b>	<ul style="list-style-type: none"> <li>■ Phone accessibility control by user PIN</li> <li>■ Intelligent phonebook (up to 500 entries in total)</li> <li>■ Remote phonebook (XML/LDAP)</li> <li>■ Intelligent contact number matching/filtering</li> <li>■ Call log (300 entries in total, in/out/missed)</li> <li>■ Voice message waiting indication (VMWI)</li> <li>■ Network time synchronization</li> <li>■ Multi-language support in screen and web UI: English, Chinese (Traditional/Simplified), Japanese, Russian, Italian, Turkish, German, Dutch, Spanish, Hebrew, Polish, French, etc.</li> </ul>
<b>Audio Features</b>	<ul style="list-style-type: none"> <li>■ HD voice microphone/speaker (handset/hands-free, 0~7KHz frequency response)</li> <li>■ Wideband ADC/DAC 16KHz sampling</li> <li>■ Narrowband codec: G.711a/u, G.723.1, G.726-32K, G.729AB</li> <li>■ Wideband codec: G.722</li> <li>■ Full-duplex acoustic echo canceller (AEC) – a tail length of 96ms in hands-free mode</li> <li>■ Voice activity detection (VAD), comfort noise generation (CNG), background noise estimation (BNE), noise reduction (NR)</li> <li>■ Packet loss concealment (PLC)</li> <li>■ Dynamic adaptive jitter buffer up to 300ms</li> <li>■ DTMF: In-band, out-of-band – DTMF-relay (RFC2833), SIP info</li> </ul>
<b>Environment</b>	
<b>Operating Temperature</b>	0 ~ 40 degrees C
<b>Operating Humidity</b>	10 ~ 65% (non-condensing)
<b>Emission</b>	CE, FCC, RoHS

# Chapter 2. Hardware Interface & Installation

## 2.1 Physical Descriptions

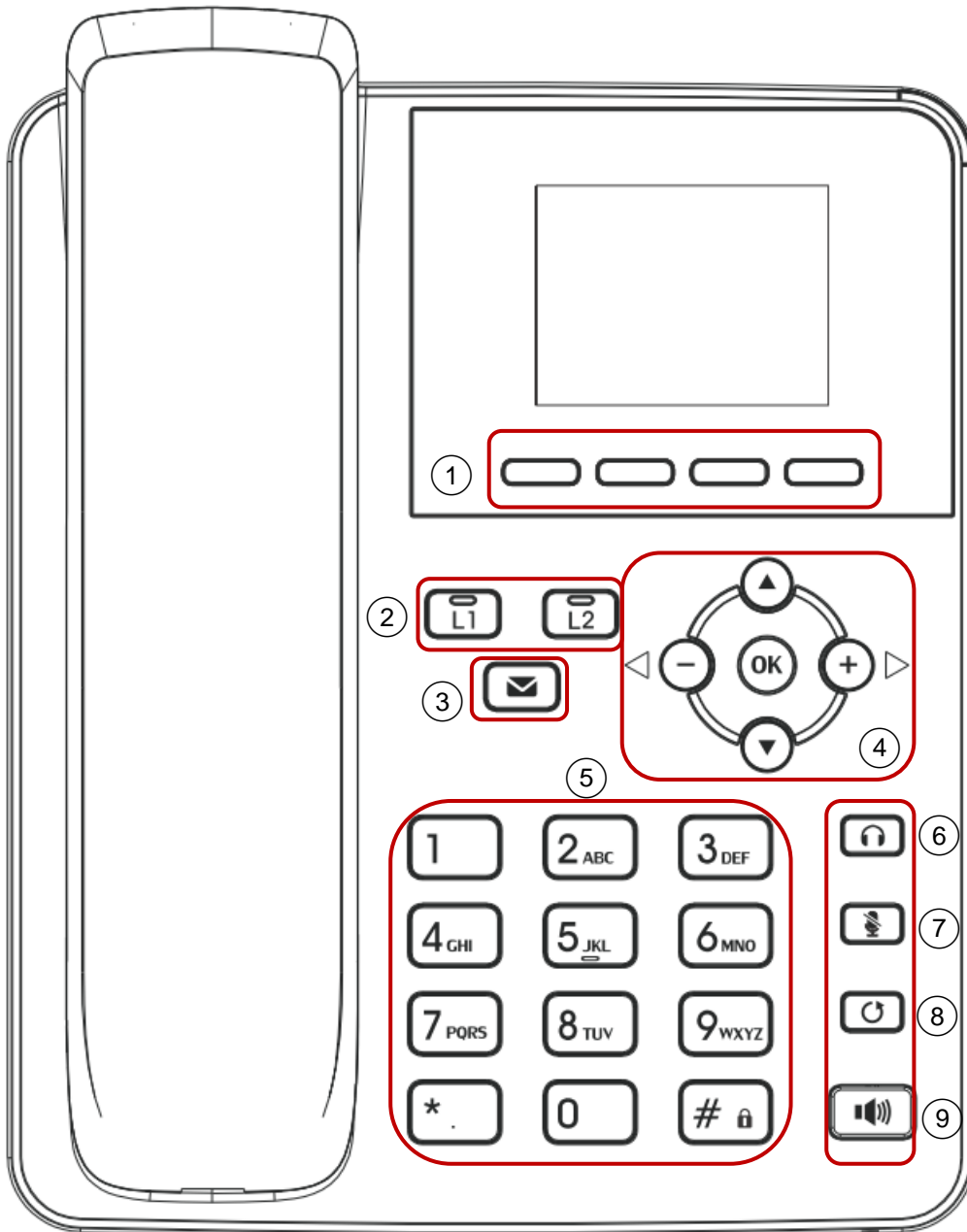


Figure 1 - Keypad

The above picture shows the keypad layout of the device. Each key provides its own specific function. User should refer to the illustration in this section about the usage of each key and the description in this document about each function.

Some keys come with long key press. User can press and hold the key for 1.5 seconds to trigger a function.

**Table 2 - Keypad Descriptions**

Interface		Description
1	<b>Soft-menu Buttons</b>	These four buttons provide different functions corresponding to the soft-menu displayed on the screen.
2	<b>Line 1 ~2 Key</b>	Switch to different SIP lines.
3	<b>MWI Key</b>	Press this button to enter the voicemail service.
4	<b>Navigation Keys</b>	User can press the up/down navigation key to change line focus on the talking screen or move the cursor to a listed item on the screen. In some configuration or text editor screen, user can press the left/right navigation key to switch option or move cursor to the left/right.
5	<b>Numeric Keypad</b>	The 12 standard telephone keys provide the same function as standard telephones, but some keys also provide special functions by long pressing the keys. Key <b>#</b> - Long press to lock the phone. (Default PIN is 123)
6	<b>Headset Key</b>	Use the headset to call out or call in
7	<b>Microphone Mute</b>	User can mute the microphone with this button in talking mode
8	<b>Redial</b>	By pressing the 'Redial' button, user can redial the last dialed number
9	<b>Hands-free Speaker</b>	By pressing this button once, user can turn on the audio channel of hands-free speaker

## 2.2 Using Handset/Hands-free Speaker/Headphone

### ■ Using Handset

To talk over handset, user should lift the handset off the device and dial the number, or dial the number first, then lift the handset and the number will be dialed. User can switch audio channel to handset by lifting the handset when audio channel is opened in speaker or headphone.

### ■ Using Hands-free Speaker

To talk over hands-free speaker, user should press the hands-free button and then dial the number, or dial the number first and then press the hands-free button. User can switch audio channel to the speaker from handset by pressing the hands-free button when audio channel is opened in handset.

### ■ Using Headphone

To use headphone, by default, user should press the headset button, which is defined by DSS key to turn on the headphone. Like the handset and hands-free speaker, user can dial the number before or after the headphone is turned on.

### ■ Using Line Keys (Defined by DSS Key)

User can use line key to make or answer a call on specific line. If handset has been lifted, the audio channel will be opened in handset, otherwise, the audio channel will be opened in hands-free speaker or headphone.

Please connect power adapter, network, PC, handset, and headphone to the corresponding ports as described in the diagram below.

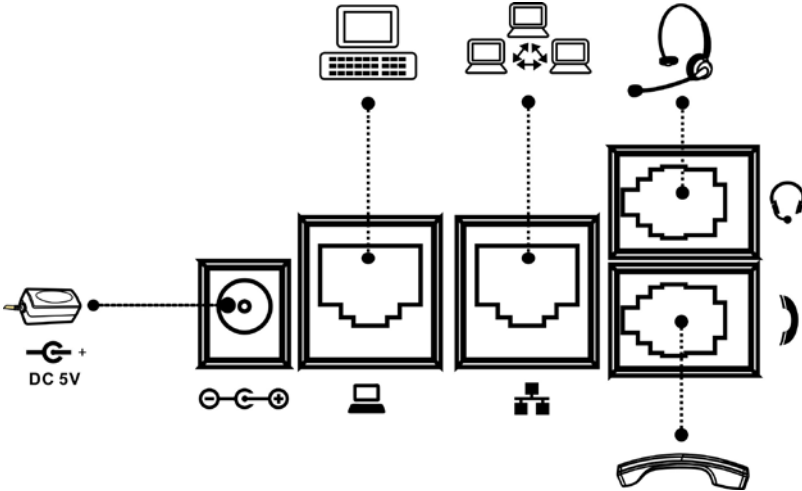
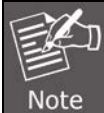


Figure 2 - Connecting to the Device

**Table 3 - Interface Descriptions**

Interface		Description
1	<b>Headset</b>	Connected to the headset interface
2	<b>Headphone</b>	Connected to the headphone interface
3	<b>Internet (WAN)</b>	Use one end of a straight Cat5 cable to directly connect to a switch/hub and the other end to the RJ45 connector for internet access. The WAN interface also can be connected with 802.3af PoE switch or converter for power supply
4	<b>PC (LAN)</b>	Use a Cat5 cable to directly connect between the RJ45 connector and a PC to maintain the existing network structure.
5	<b>DC 5V</b>	Power port (This unit does not include the 5V/600mA power adapter)



Power adapter is optional for VIP-1120PT model. (This unit does not include the 5V/600mA power adapter.)

### 2.3 Desktop and Wall-mount Installation

The device supports two installation modes, desktop and wall-mount. To set up the phone on the desktop, please follow the instructions as shown in the diagrams below.

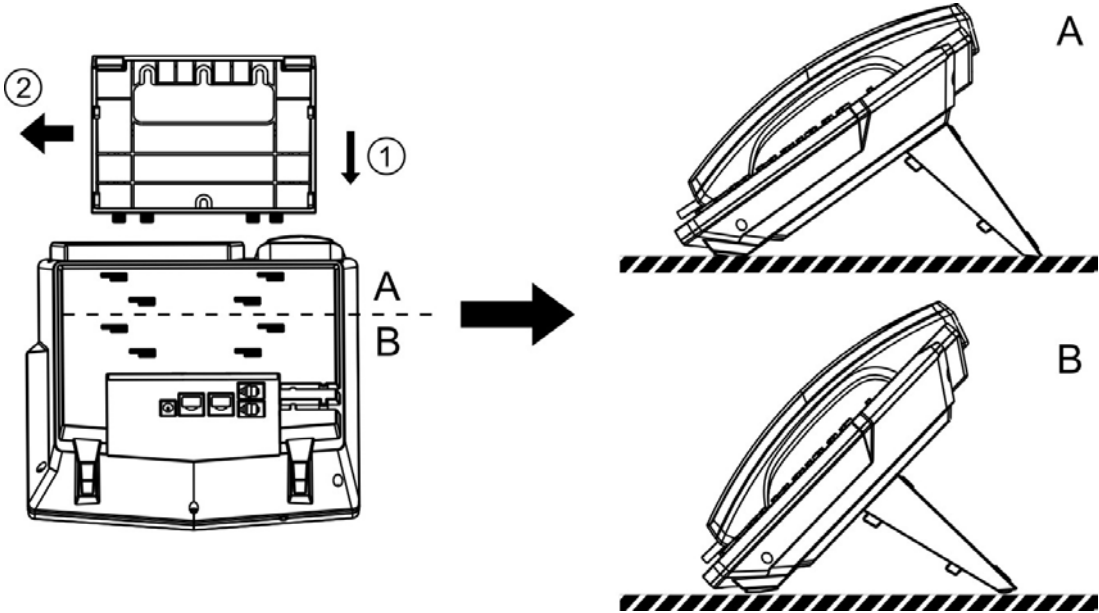


Figure 3 - Desktop Installation

To mount the device on the wall, please follow the instructions shown in the pictures below..

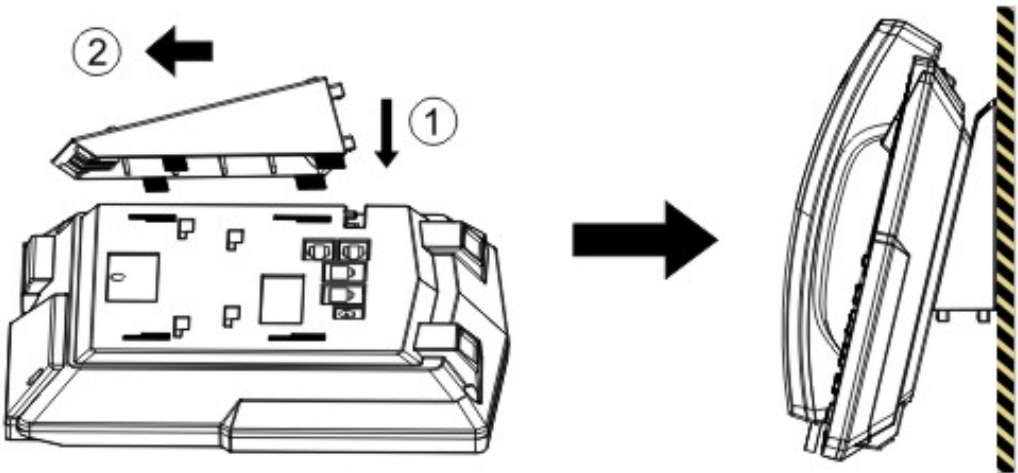
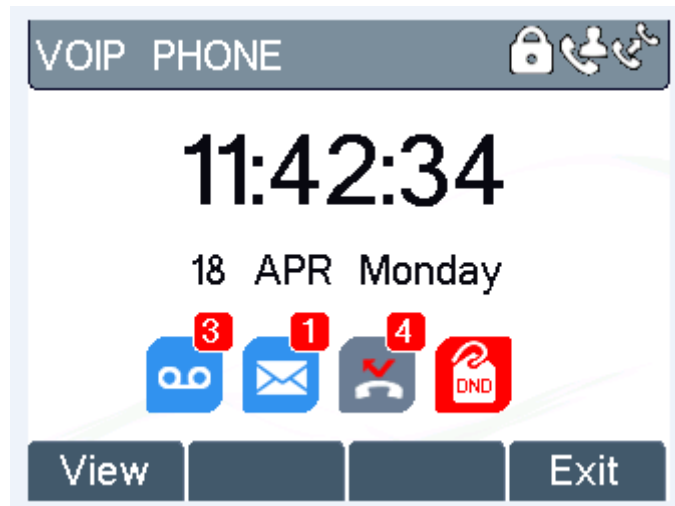


Figure 4 - Wall-mount Installation

# Chapter 3. Introduction to the Phone User Interface

## Interface

### 3.1 Screen User Interface



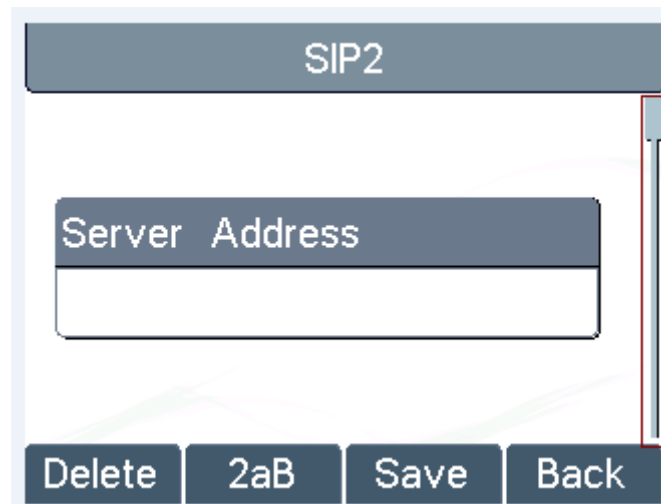
*Figure 5 - Screen Layout / Default Standby Screen*

The screen user interface is mostly presented in the above layout except some prompt messages. The upper area is the main screen to display the device's status and information or data for viewing or editing. The lower area is the software menu (soft-menu) buttons which will change against user's action or device's status.

The above picture shows the default standby screen which is also the root of the soft-menu. The default standby screen shows the greeting words and effective feature indications like voice message, missed call, auto-answering, do-not-disturb, call forward, lock state, and the network connectivity. User can get back to the default standby screen mostly by lifting and putting by the handset.

The icon illustration is described in **Appendix I - Icon Illustration**.

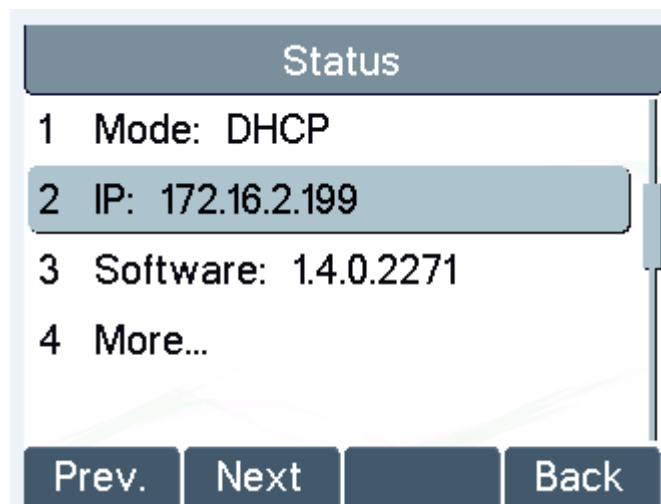
In some screens, there are more items or long text to be displayed which could not fit into the screen. They will be arranged in a list or multiple lines with a scroll bar. If user sees a scroll bar, user can use up/down navigation buttons to scroll the list. By pressing the navigation keys a little longer, user can scroll the list or items at a faster speed.



**Figure 6 - Vertical Scroll Bar**

## 3.2 Web Portal

User can also use the device's web portal to manage or operate the device. User should open the device's web portal page by entering the device's IP address in a browser. To get the device IP address, user could press the soft-menu button [Menus] -> [Status] or by pressing the [Down] navigation key.



**Figure 7 - Check the Device's IP Address**



The first screen of the device's web portal is the login page.



*Figure 8 - Web Portal Login Page*

**Default IP Address:** 172.16.0.1

**Default username:** admin

**Default password:** 123

User must enter the username and password to log in to the web portal. **The default username and password is “admin” and “123”.** For details on web portal operations, please refer to **Chapter 7 Web Portal.**



# Chapter 4. IP Phone Setup

In order to get the device ready for making and receiving phone calls, the device must be configured with correct network configurations and at least one of the lines must be configured with an IP telephony service.

## 4.1 Network Configuration


The device relies on IP network connection to provide service. Unlike traditional phone system based on a circuit switched wire technology, IP devices are connected to each other over the network and exchange data in packet basis based on the devices' IP address.

To enable the device, the network parameters must be configured properly first. To configure network parameters, user should open the network configuration screen through soft-menu [Menu] -> [Settings] -> [Advanced Settings] -> [Network] -> [Network Settings] from standby screen.

 Note	 If user see a 'Network Disconnected' icon flashing in the middle of screen, it means the network cable is not correctly connected to the device's network port. Please check whether the cable is connected correctly to the device and to the network switch, router, or modem.
---	---

There are three common IP configuration modes.


- **Dynamic Host Configuration Protocol (DHCP)** -- This is the automatic configuration mode by getting network configurations from a DHCP server. Users need not to configure any parameters manually. All configuration parameters will be getting from DHCP server and applied to the device. This is recommended for most users.
- **Static IP Configuration** -- This option allows user to configure each IP parameter manually, including IP address, subnet mask, default gateway, and DNS servers. This is usually used in an office environment or by power users.
- **PPPoE** -- This option is often used by users who connect the device to a broadband modem or router. To establish a PPPoE connection, user should configure username and password provided by the service provider.

 Note	The device is default configured in <b>Static</b> mode; the default IP address is <b>172.16.0.1</b>
---	---

## 4.2 Line Configurations

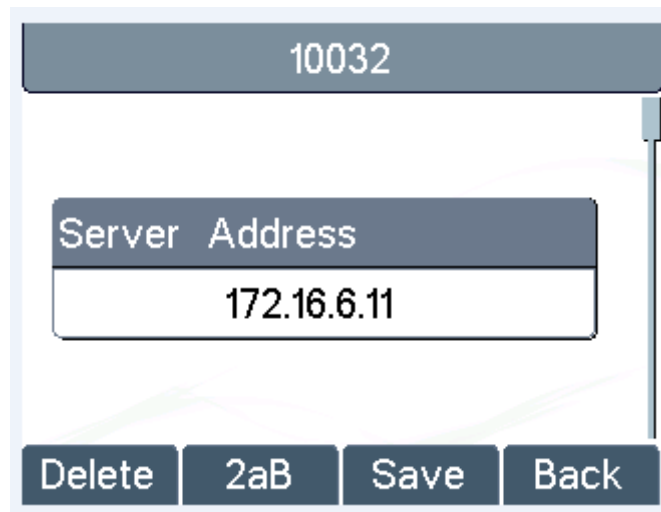
A line must be configured properly to be able to provide telephony service. The line configuration is like a virtualized SIM card. Just like a SIM card on a mobile phone, it stores the service provider and the account information used for registration and authentication. When the device is applied with the configuration, it will register the device to the service provider with the server's address and user's authentication as stored in the configurations.

To configure a line manually, user may open the line configuration screen through soft-menu button [Menu] -> [Settings] -> [Advanced Settings] -> [Accounts] -> [SIP1] / [SIP2] -> [Basic Settings] from the standby screen.

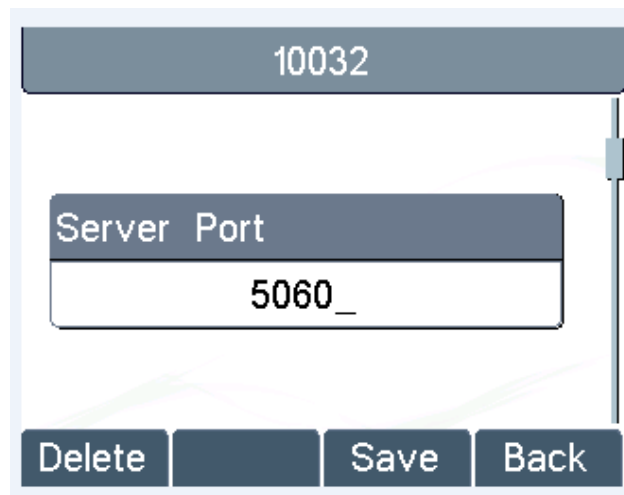


**Note** User must enter the correct PIN code to be able to go to advanced settings to edit line configuration. (The default PIN is **123**.)

The parameters and screens are listed in the diagrams below.



**Figure 9 - Configure SIP Proxy Server Address**



10032

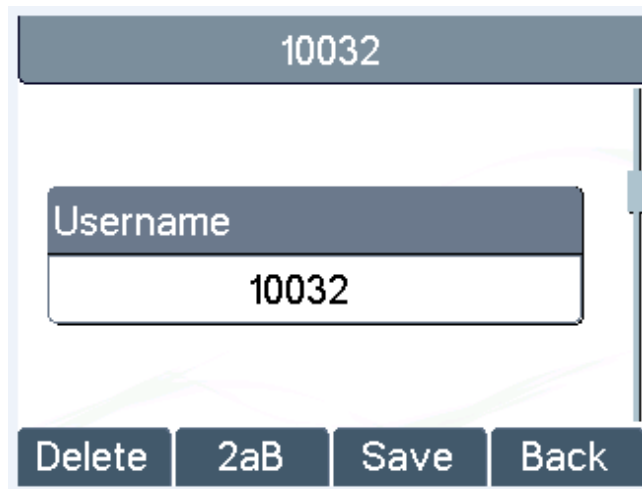
Server Port

5060\_

Delete Save Back

This screenshot shows a configuration screen for SIP Proxy Server Port. At the top, there is a header bar with the number '10032'. Below it, a form field labeled 'Server Port' contains the value '5060\_'. At the bottom, there are four buttons: 'Delete', 'Save', and 'Back'.

**Figure 10 - Configure SIP Proxy Server Port**



10032

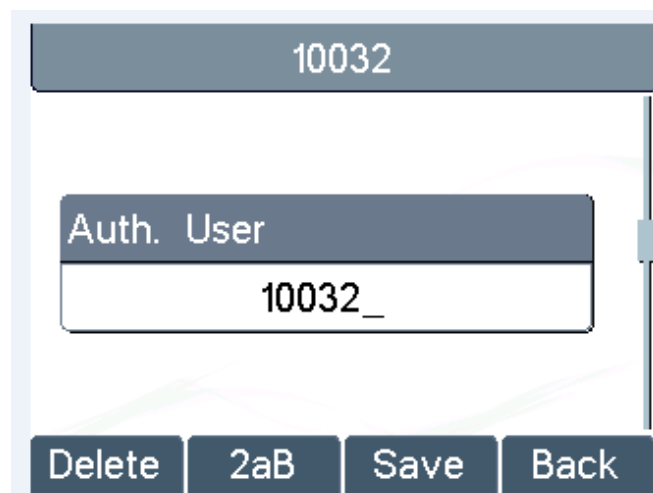
Username

10032

Delete 2aB Save Back

This screenshot shows a configuration screen for SIP Username. At the top, there is a header bar with the number '10032'. Below it, a form field labeled 'Username' contains the value '10032'. At the bottom, there are four buttons: 'Delete', '2aB', 'Save', and 'Back'.

**Figure 11 - Configure SIP Username**



10032

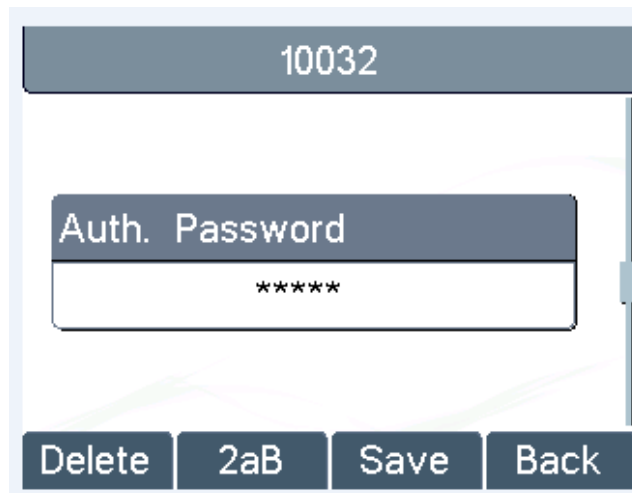
Auth. User

10032\_

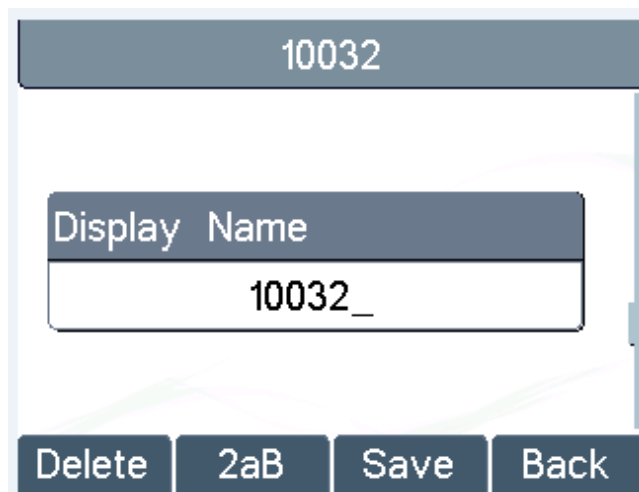
Delete 2aB Save Back

This screenshot shows a configuration screen for Authentication Name. At the top, there is a header bar with the number '10032'. Below it, a form field labeled 'Auth. User' contains the value '10032\_'. At the bottom, there are four buttons: 'Delete', '2aB', 'Save', and 'Back'.

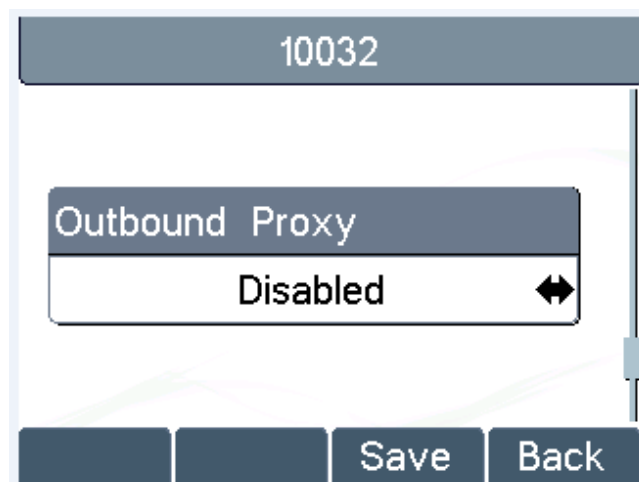
**Figure 12 - Configure Authentication Name**



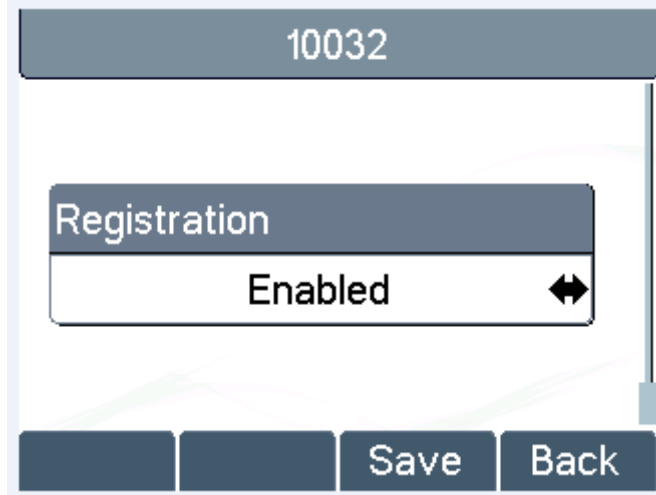
**Figure 13 - Configure SIP Authentication Password**



**Figure 14 - Configure Display Name**



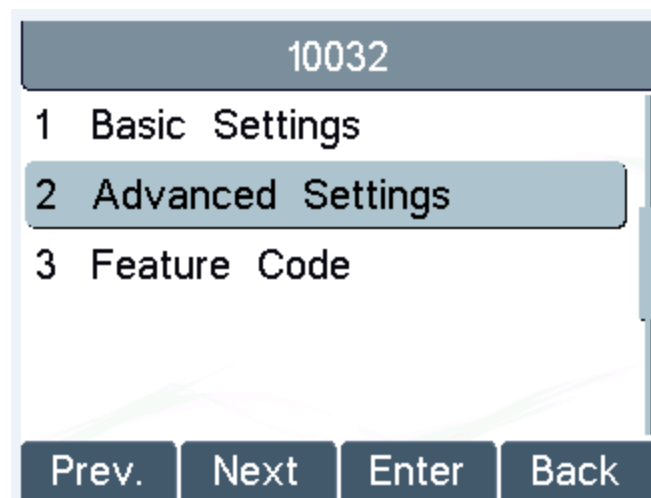
**Figure 15 - Enable/Disable Outbound Proxy**



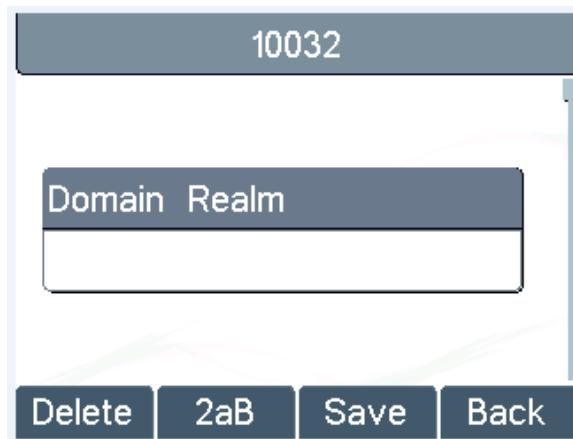
**Figure 16 - Enable/Disable SIP Line**

Save the adjustment by pressing [OK] or [Save] when done.

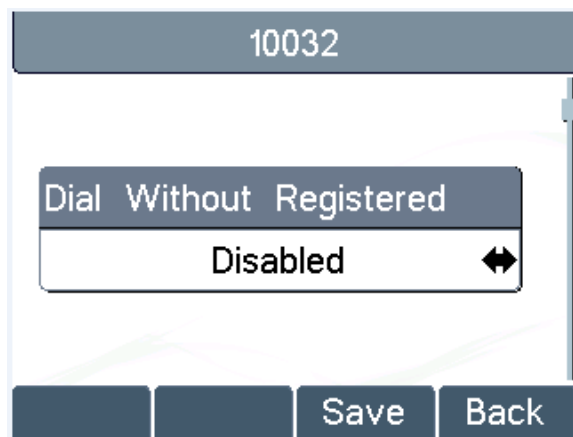
For users who want to configure more options, user should use web management portal to modify or Advanced Settings in accounts on the individual line to configure those options.



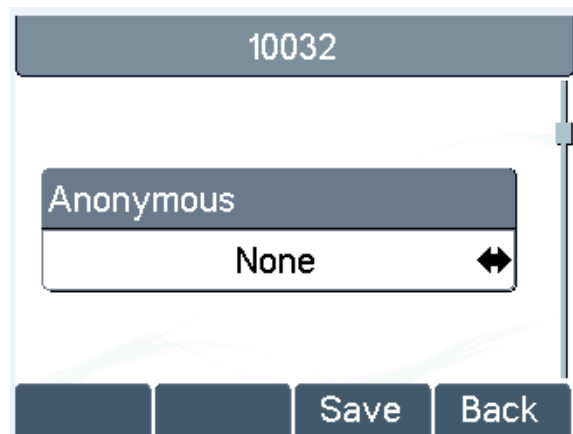
**Figure 17 - Configure Advanced Line Options**



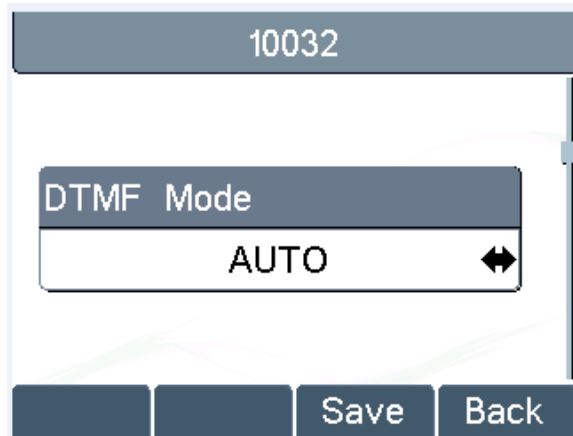
**Figure 18 - Configure SIP Realm/Domain**



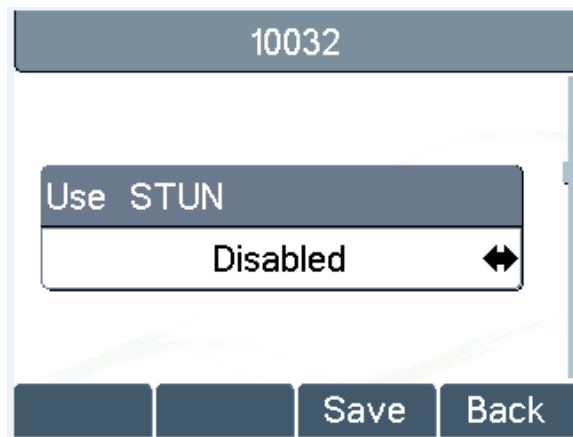
**Figure 19 - Configure Unregistered Dial**



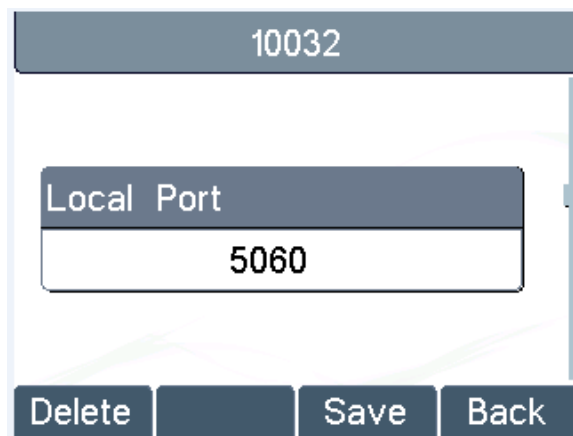
**Figure 20 - Enable/Disable Anonymous**



**Figure 21 - Configure DTMF Mode**

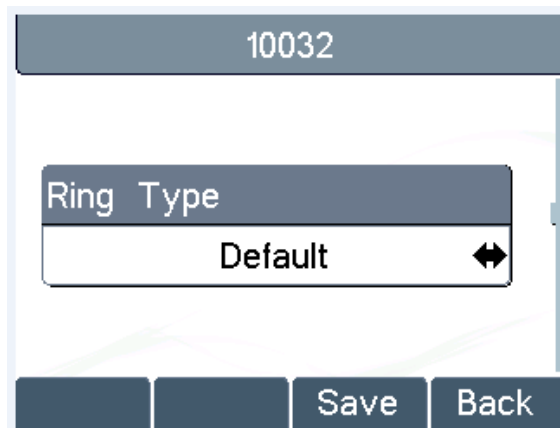


**Figure 22 - Enable/Disable STUN**

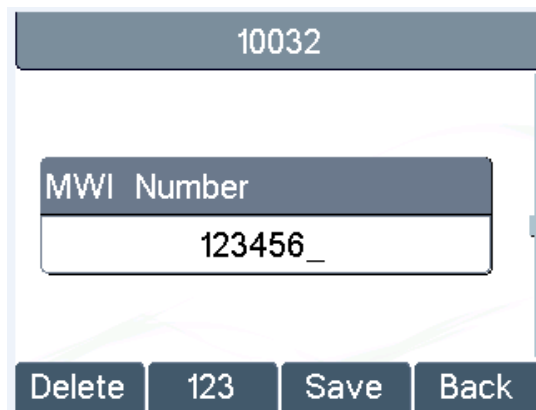


**Figure 23 - Configure Local Port**

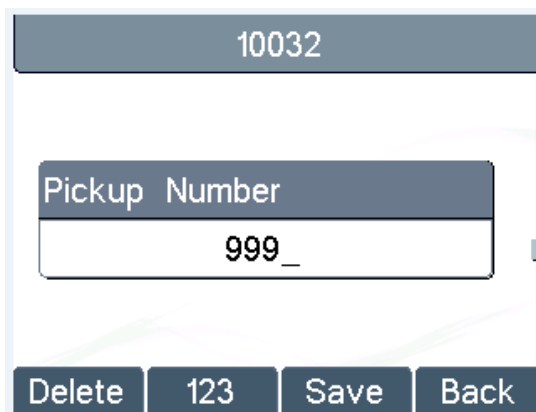




**Figure 24 - Configure Ring Type**



**Figure 25 - Configure MWI Number**



**Figure 26 - Configure Pickup Number**

10032

Park Number

888

Delete 123 Save Back

**Figure 27 - Configure Park Number**

10032

Join Call Number

\*97\_

Delete 123 Save Back

**Figure 28 - Configure Join Call Number**

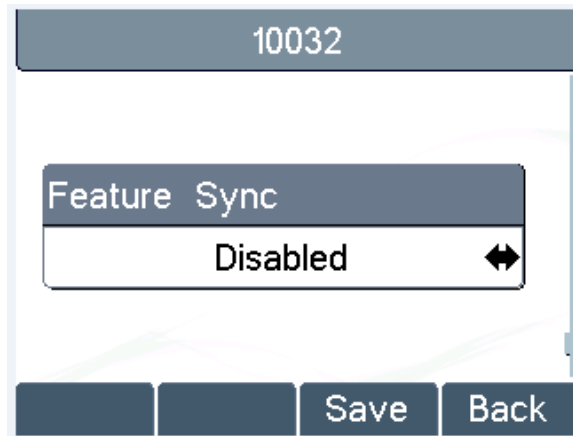
10032

Missed Call Logs

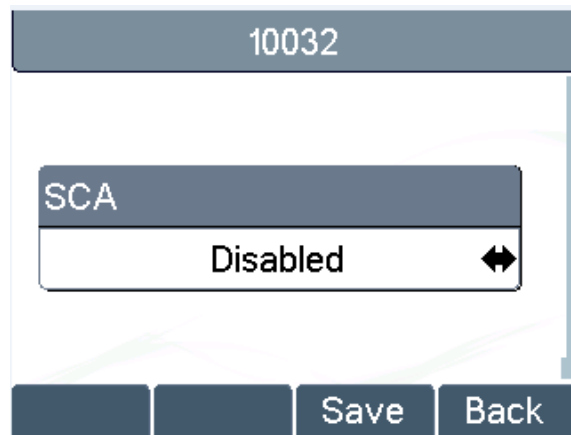
Enabled ↔

Save Back

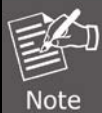
**Figure 29 - Enable/Disable Missed Call**



*Figure 30 - Enable/Disable Feature Sync*



*Figure 31 - Enable/Disable SCA*



Note

On the device, user can only configure whether STUN/Outbound Proxy is enabled to change the STUN/Outbound Proxy server address. User must edit in the device web portal. **(Refer to 7.15 LINES (Global Settings) and 7.12 LINES (SIP))**

# Chapter 5. Using the Phone

## 5.1 Making Phone Calls

### ■ Default Line

The device provides 2 line services. If both lines are configured, user can make or receive phone calls on either line. If default line is configured by user, there will be a default line to be used for making outgoing call which is indicated on the top left corner. To change the default line, user can press the left/right navigation button to switch between two lines. To enable or disable default line, user can press [menu] -> [Features] -> [Default Line] or configure from Web Interface (Web/PHONE Settings/Features).



*Figure 32 - Default Line*

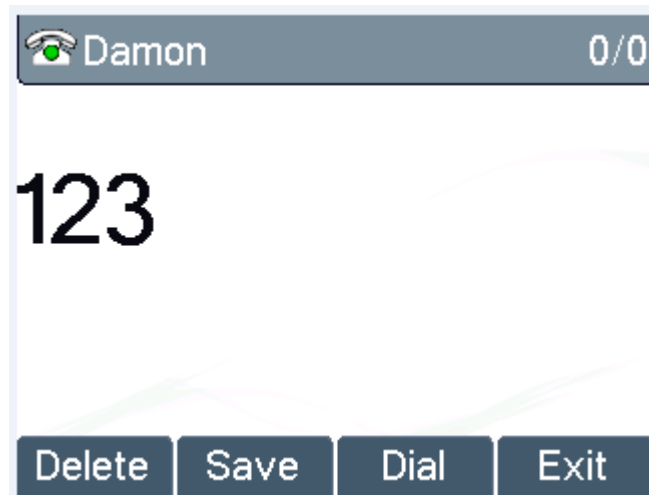
### ■ Dialing Methods

User can dial a number by,

- Entering the number directly
- Selecting a phone number from phonebook contacts (Refer to **5.5 Using Phonebook**)
- Selecting a phone number from cloud phonebook contacts (Refer to **5.9 Using Cloud Phonebook**)
- Selecting a phone number from call logs (Refer to **5.11 Call Logs**)
- Redialing the last dialed number

■ **Dialing Number then Opening Audio**

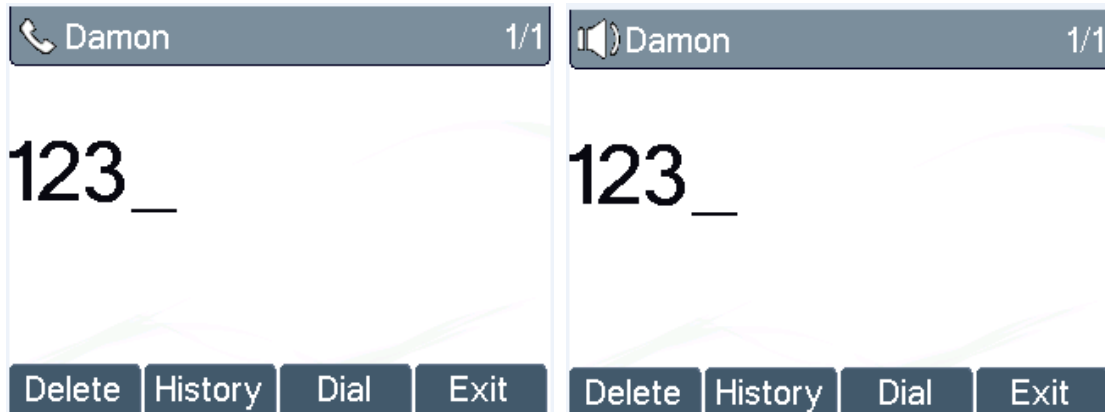
To make a phone call, user can firstly dial a number by one of the above methods. When the dialed number is completed, user can press the [Dial] button on the soft-menu, or press the hands-free button to turn on the speaker or headphone, or lift the handset to call out with the current line, or user can press the line key to call out with a specified line.



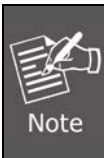
*Figure 33 - Dialing a Number before Audio Channel Opened*

■ **Opening Audio and then Dialing the Number**

Another alternative is the traditional way to firstly open the audio channel by lifting the handset, turning on the hands-free speaker or headphone by pressing hands-free button, or line key, and then dial the number with one of the above methods. When the number is dialed completely, user can press the [Dial] button or [OK] button to call out, or the number will be dialed out automatically after timeout.



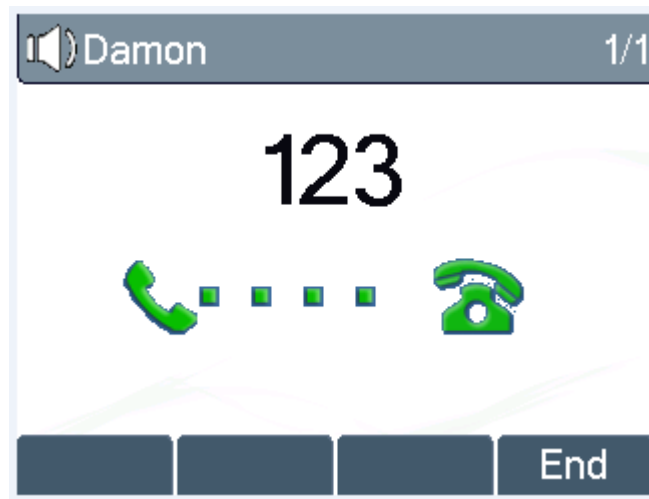
*Figure 34 - Dial a Number after Audio Channel Opened*



For some users who get used to dial a number immediately by pressing **#** key, the user must login to the web to enable 'Press "#" to invoke dialing' option in page [Line] -> [Dial Plan] -> "Basic Settings" and apply it.

### ■ Cancel Call

While calling the number, user can press the [End] button or close the audio channel by putting back the handset or press the hands-free button to end the call.



*Figure 35 - Calling Remote Party*

### ■ Answering Incoming Call

When there is an incoming call while the device is idle, user will be alerted to the following incoming call on the screen.



*Figure 36 - Incoming Call Screen*

User can answer the call by lifting the handset, open headphone or speaker phone by pressing the hands-free button, or the [OK] / [Answer] button. To divert the incoming call, user should press the [Divert] button. To reject the incoming call, user should press the [Reject] button.

## ■ Talking

When the call is connected, user will see a talking mode screen as shown in the following figure.

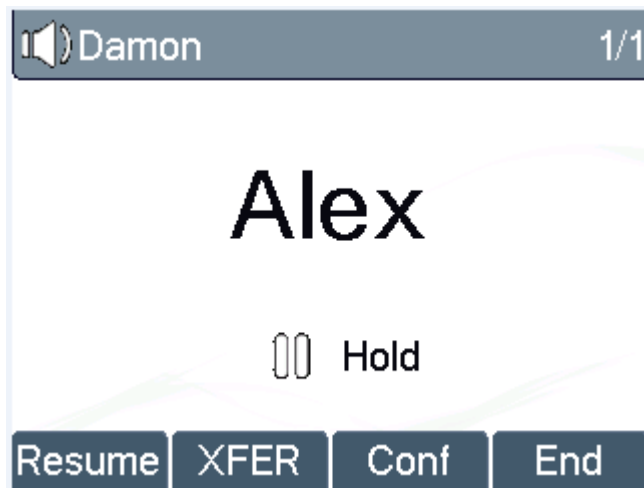


**Figure 37 - Talking Mode Screen**

- 1. Audio Channel** -- The icon reflects the current audio channel being used.
- 2. Current Line** -- The line is being used on the call.
- 3. Remote Party** -- The name or number of the remote party.
- 4. Talking time** -- The time has passed since the call was established.
- 5. Screen Pages** -- The number of screen pages. User can press the up/down navigation buttons to switch screen page.

## ■ Call Holding/Resuming


User can hold the remote party by pressing the [Hold] button and the button will be changed to [Resume] icon. User can press the [Resume] button to resume the call.



**Figure 38 - Call Holding Screen**

### ■ Call Ended

When user finishes the call, user can put the handset back to the device to hang up the call or press the hands-free button to close the audio channel to hang up.

 <p>Note</p>	When the call is held or in holding state, the user must press the [Resume] button to return to call mode, or putting the handset back to the device or pressing the speaker-free button to hang up is not available.
---	---

## 5.2 Make/Receive Second Call

The device can support up to two concurrent calls. When there is already a call established, user can still answer another incoming call on either lines or make a second call on either lines.

### ■ Second Incoming Call

When there is another incoming call during talking a phone call, this call will be waiting for user to answer it. User will see the call message in the middle of the current screen. The device will not be ringing but playing call waiting tone in the audio channel of the current call and the LED will be flashing in green. User can accept or reject the call which is the same as normal incoming call. When the waiting call is answered, the first call will be put on hold automatically.





**Figure 39 - Second Incoming Call Screen**

■ **Second Outgoing Call**

To make a second call, user may press the [XFER] / [Conf] button to make a new call on the default line or press the line key to make new call on a specific line. Then dial the number the same way as making a phone call. Another alternative for making second call is to press the DSS Keys dialing out from the configured Keys (BLF/Speed Dial). When user is making a second call with the above methods, the first call could be placed on hold manually first or will be put on hold automatically at the second dial.

■ **Switching between Two Calls**

When there are two calls established, user will see a dual call screen as shown in the following picture.



**Figure 40 - Dual Calls**

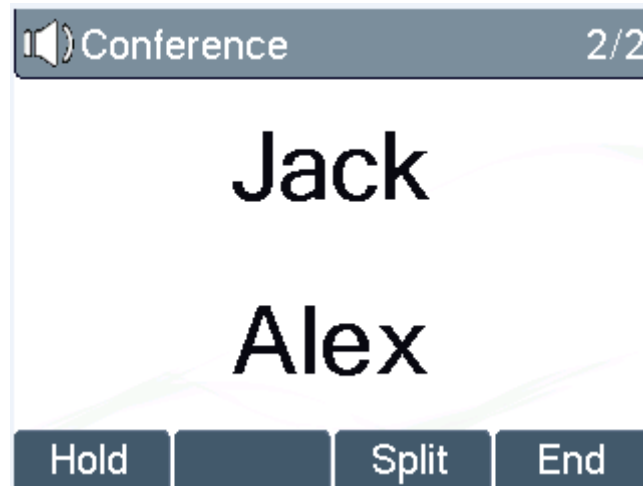
User can press the up/down navigation button to switch screen page, and switch call focus by pressing the [Hold] / [Resume] button.

### ■ Ending One Call

User may hang up the current call by closing the audio channel or press the [End] button. The device will return to single call mode in holding state.

## 5.3 Join/Split Two Calls (3-way Local Conference)

In the dual call mode, user can join two calls into a conference call by pressing the [Conf] button. When two calls are joined, user can split them by pressing the [Split] button.



*Figure 41 - Conference Call*

## 5.4 Call Transfer

When the user is talking with a remote party and wish to transfer the call to another remote party, there are two ways to transfer the call, attended and unattended.

### ■ Attended Transfer

The attended call transfer is also known as the 'polite mode' which is to dial through the other remote party, wait for the remote party to answer the call and then transfer the call.


This is the same procedure as making two concurrent calls. In the dual call mode, press the [XFER] button to transfer the first party to the second one.

### ■ Unattended/Blind Transfer

Unattended transfer is also known as 'Fire and Forget' mode. Instead of connecting to the second party

first and confirming the second call is established, user press the [XFER] button first and then dial the second party number. When the number is dialed, user can press the [XFER] button again and the first party will be transferred to the second.

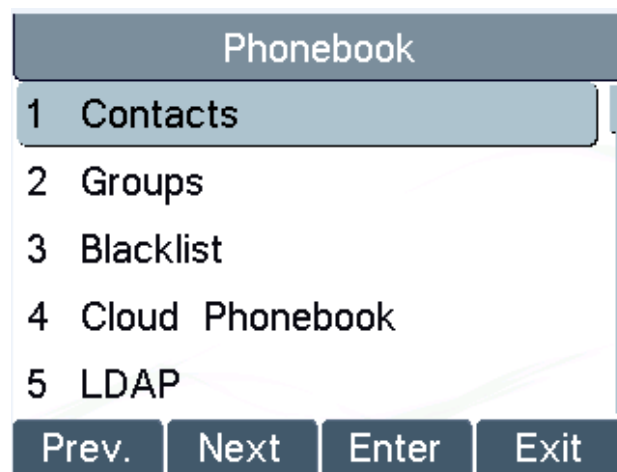
This is like helping the first party to dial to the second one. However, the transfer could be successful if the second party answered it, or could be failed if the second party is busy or rejected it.

 More advanced transfer configuration, please refer to **7.14 LINES (Dial Plan)**

## 5.5 Using Phonebook

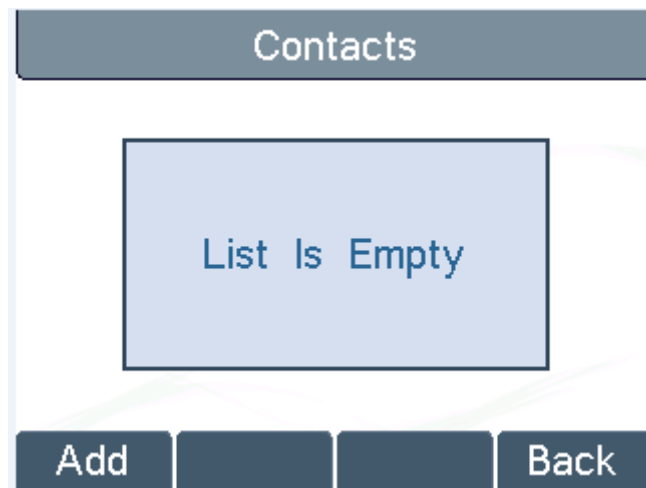
User can save contacts' information in the phonebook and dial the contact's phone number(s) from the phonebook. To open the phonebook, user can press the soft-menu button [Dir] in the default standby screen or keypad.

By default the phonebook is empty, user may add contact(s) to the phonebook manually or from call logs.



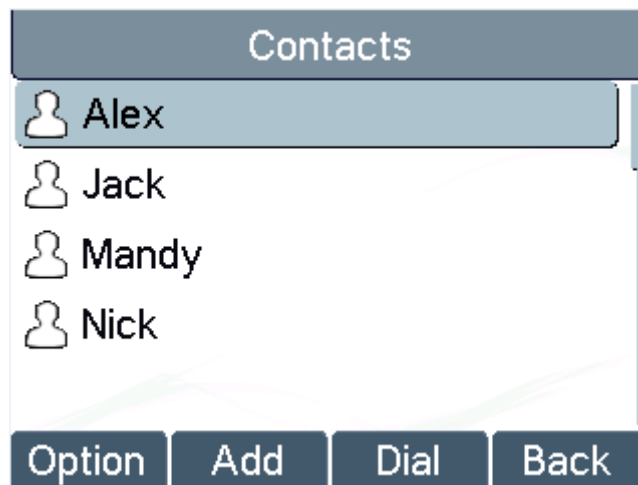
*Figure 42 - Phonebook screen*

 The device can save up to a total of 500 contacts.



**Figure 43 - Phonebook is Empty**

When there are contact records in the phonebook, the contact records will be arranged in the alphabet order. User may browse the contacts with the up/down navigation keys. User may fast scroll the contact list by holding the up/down navigation keys. The record indicator tells user which contact is currently focused. User may check the contact's information by pressing the [OK] button.



**Figure 44 - Browsing Phonebook**

## 5.6 Add/Edit/Delete Contact

To add a new contact, user should press the [Add] button to open Add Contact screen and enter the following contact information:

- Contact Name
- Tel. Number
- Mobile Number
- Other Number
- Ring Tone
- Contact Group

Contacts	
Name	Frank
Tel	4567
Mobile	
Other	
Ring	Default
Delete	123
Save	Back

**Figure 45 - Add New Contact**

User can edit a contact by pressing the [Option] -> [Edit] button.

To delete a contact, user should move the record indicator to the position of the contact to be deleted, press the [Option] -> [Delete] button and confirm with [Yes].

## 5.7 Add/Edit/Delete Group

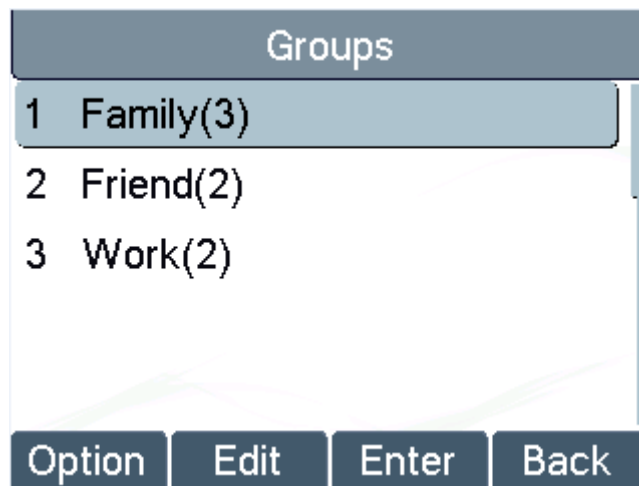
User can open the group list by pressing the [Groups] button in phonebook screen.

By default, the group list is blank. User can create his/her own groups, edit the group name, add or remove contacts in the group, and delete a group.

To add a group, press the [Add] button.

To delete a group, press the [Option] -> [Delete] button.

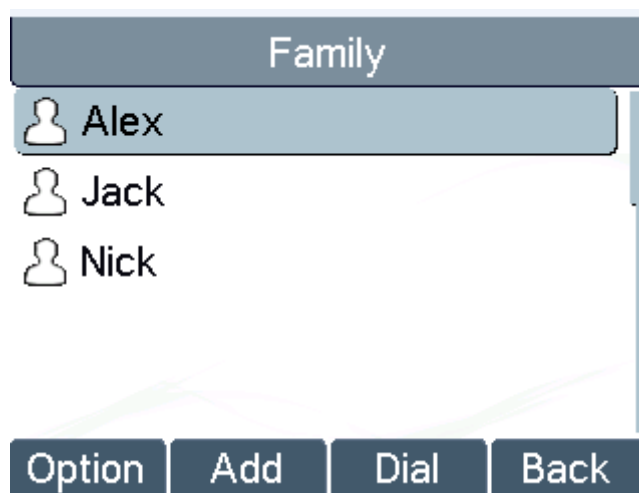
To edit a group, press the [Edit] button.



*Figure 46 - Group List*

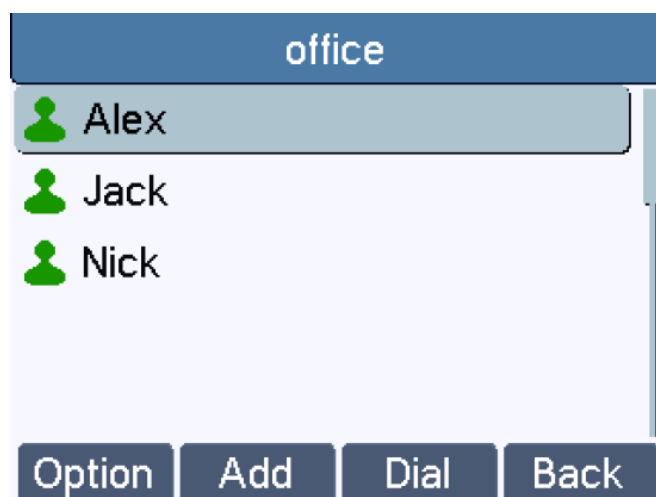
## 5.8 Browse and Add/Remove Contacts in Group

User can browse contacts in a group by opening the group in group list with the [OK] button.



*Figure 47 - Browsing Contacts in a Group*


When user is browsing contacts of a group, user can also add or remove contacts in that group by pressing the [Add] button to enter the group contacts management screen. Press the [Add] button to create a new contact for the group; press the [Option] button to remove the contact from the group.



*Figure 48 - Add/Remove Contacts in a Group*

## 5.9 Using Cloud Phonebook

Cloud phonebook allows user to configure the device to download a phonebook from a cloud server. This is very useful for office users to use the phonebook from a single source and save the effort to create and maintain the contact list individually. It is also a useful tool for user to synchronize his/her phonebook from a personal mobile phone to the device with Cloud Phonebook Service which is to be provided publicly soon.

 Note	The cloud phonebook is ONLY temporarily downloaded to the device each time it is opened on the device to ensure the user gets the up-to-date phonebook. However, the downloading may take a couple of seconds depending on the network condition. Therefore, it is highly recommended to the users to save important contacts from cloud to local phonebook to save the time of waiting for downloading.
---	--

To open cloud phonebook list, press [Cloud Phonebook] in phonebook screen.



*Figure 49 - Cloud Phonebook List*

## 5.10 Open Cloud Phonebook

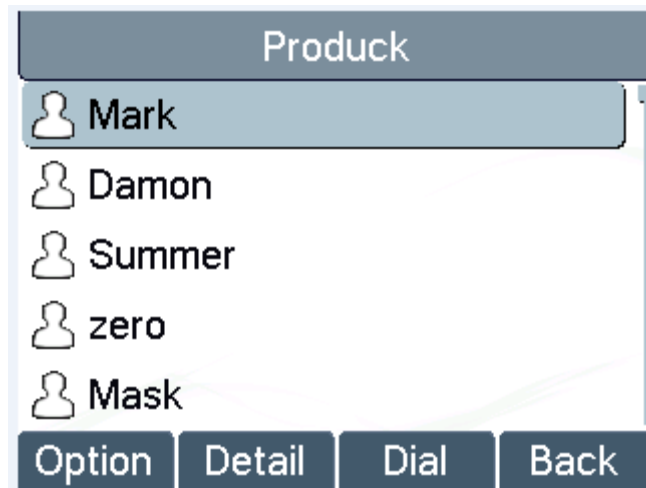
In cloud phonebook screen, user can open a cloud phonebook by pressing the [OK] / [Enter] button. The device will start downloading the phonebook. If downloading failed, user will be prompted with a warning message.

Once the cloud phonebook is downloaded completely, user may browse the contact list and dial the same contact number as in local phonebook.



*Figure 50 - Downloading Cloud Phonebook*





**Figure 51 - Browsing Contacts in Cloud Phonebook**

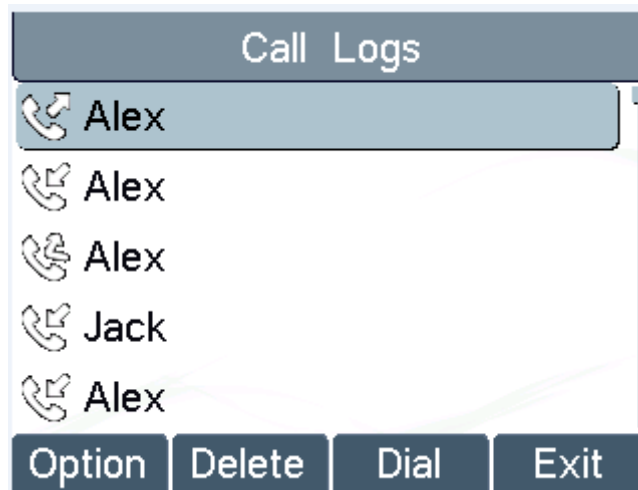
## 5.11 Call Logs

The device can store up to 600 call log records and user can open the call logs to check all incoming, outgoing, and missed call records by pressing the soft-menu button [History].

In the call logs screen, user may browse the call logs with the up/down navigation keys.

Each call log record is presented with 'call type' and 'call party number/name'. User can check further call log detail by pressing the [OK] button and dial the number with the [Dial] button, or add the call log number to phonebook by pressing [Option] -> [Add to Contact] .

User can delete a call log by pressing the [Delete] button and can clear all call logs by pressing the [Clear] button.



**Figure 52 - Call Logs**

User can also filter call logs with specific call log type to narrow down the call log records by pressing the left/right navigation button and select one of the call log types in the soft-menu buttons.




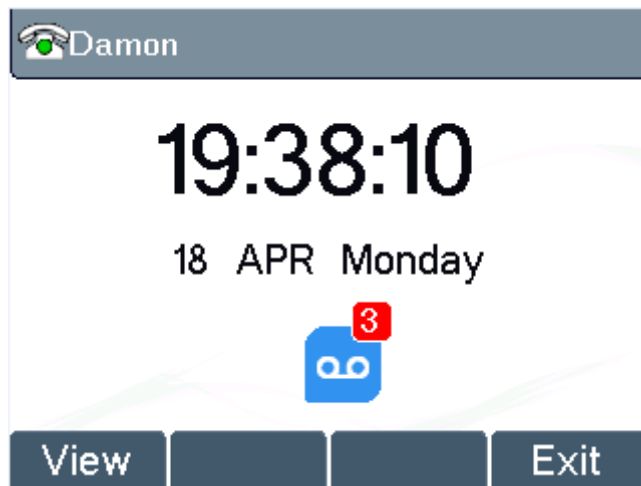
-  - Missed Calls
-  - Received Calls/Incoming Calls
-  - Dialed Calls/Outgoing Calls



Figure 53 - Filter Call Log Type

### 5.12 Voice Message

If the service of the lines supports voice message feature, when the user is not available to answer the call, the caller can leave a voice message on the server to the user. User will receive voice message notification from the server and device will prompt a voice message waiting icon on the standby screen,

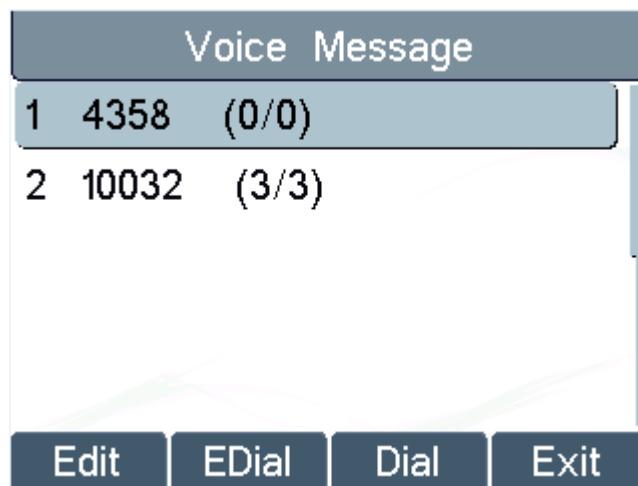


**Figure 54 - New Voice Message Notification**

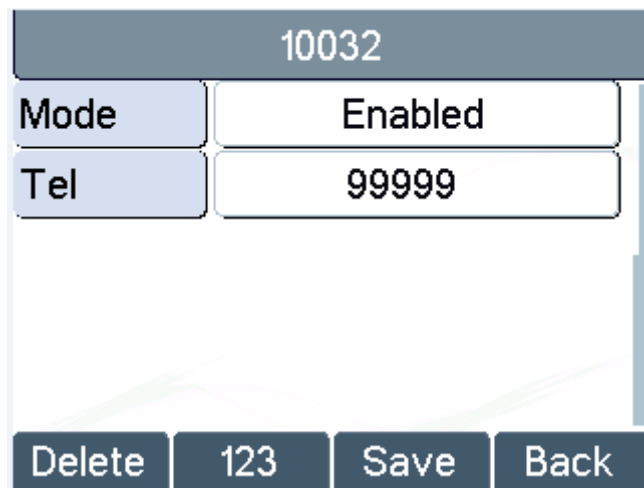
To retrieve the voice messages, user must configure the voice message number first. Once the voice message number is configured, user can retrieve the voice message of a line by pressing the [Dial] button in the voice message screen.

When the device is in the default standby mode,

- Check the [MWI] button.
- Press the [MWI] button to open voice message configuration screen, select the line to be configured with the up/down navigation keys.
- Press the [Edit] button to enable and edit the voice message number, when done, press the [OK] / [Save] button to save the configuration.



**Figure 55 - Voice Message Screen**





**Figure 56 - Configure the Voice Message Number**

## 5.13 Do-Not-Disturb

User may enable Do-Not-Disturb (DND) feature on the device to reject incoming calls (including call waiting). The DND can be enabled on line basis.

To quickly enable or disable the DND on all lines,


When the device is in the default standby mode,

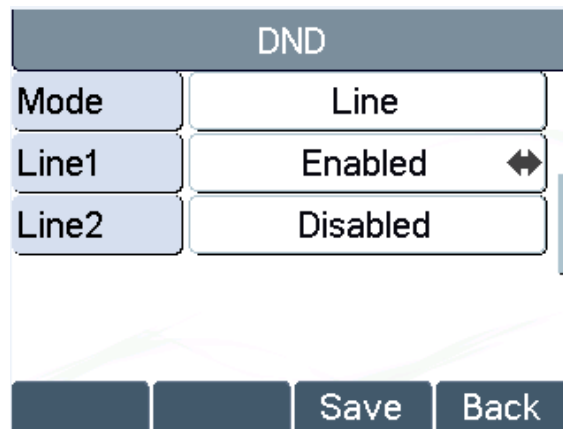
- Press the [DND] button to enable DND on all lines and icon  will be displayed on the screen.
- Press the [DND] button again to disable DND on all lines and icon  will be disappeared.



**Figure 57 - DND Enabled on All Lines**

If user wishes to enable or disable DND on a specific line, user could change the DND mode in DND configurations.

- Press the soft-button [Menu] till you find the [Features] item.
- Enter [Features] item till you find the [DND] item.
- Enter [DND] item till you find [DND item].
- Press the left/right navigation key to change the DND mode or DND state on specific line. When done, press the [Save] button to save the changes.
- User will see icon  'SIP Do Not Disturb' against the enabled line.



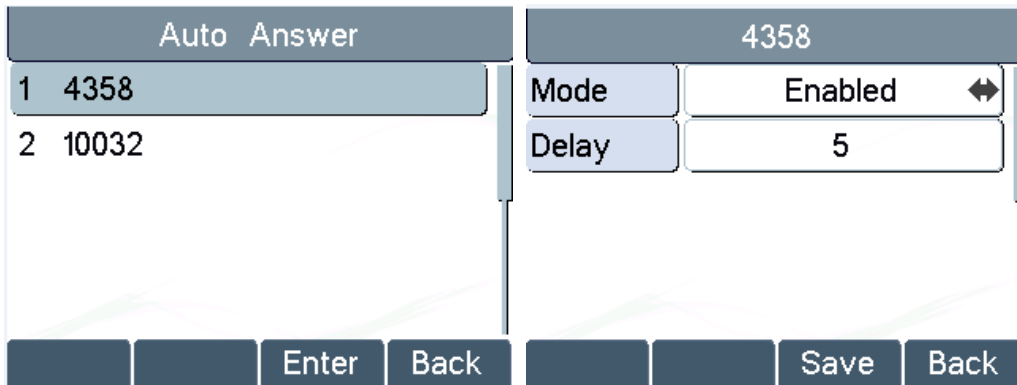
*Figure 58 - Configure DND on Line*

## 5.14 Auto-Answering

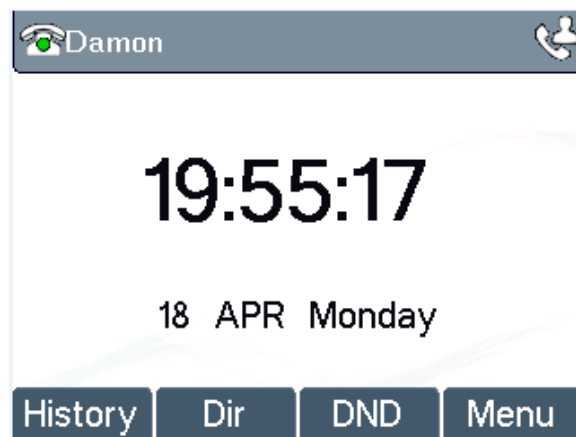
User may enable auto-answering feature on the device and any incoming call will be automatically answered (not including call waiting). The auto-answering can be enabled on line basis.

When the device is in the default standby mode, if user wishes to enable or disable auto-answering on a specific line or change the auto-answering delay time, user could change the auto-answering configuration by adopting the following steps:

- Press soft-button [Menu] till you find the [Features] item.
- Enter [Features] item till you find the [Auto Answer] item.
- Enter [Auto Answer] item to change the auto-answering configuration on a specific line
- Press the left/right navigation button to select the auto-answering option. When done, press the [Save] button to save the changes.
- The default auto-answering delay is 5 seconds.



**Figure 59 - Configure Auto-answering on Line1**



**Figure 60 - Auto-answering Enabled on Line1**

## 5.15 Call Forward

Call forward is also known as 'Call Divert' which is to divert the incoming call to a specific number based on the conditions and configurations. User can configure the call forward settings of each line.

There are three types:

- **Unconditional Call Forward** -- Forward any incoming call to the configured number.
- **Call Forward on Busy** -- When user is busy, the incoming call will be forwarded to the configured number.
- **Call Forward on No Answer** -- When user does not answer the incoming call after the configured delay time, the incoming call will be forwarded to the configured number.

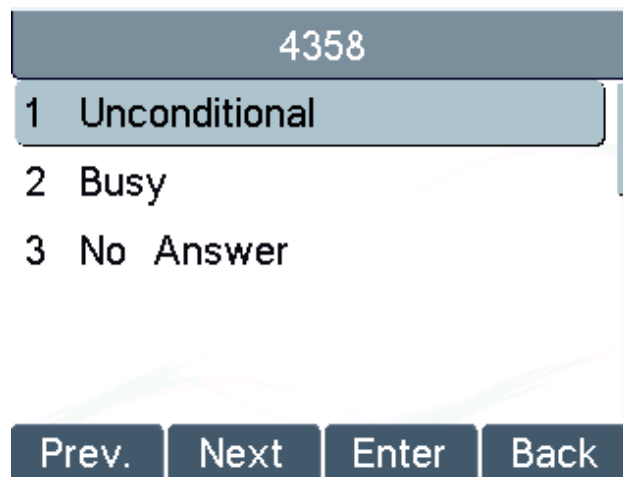
To configure call forward, when the device is in the default standby mode,

- Press soft-button [Menu] till you find the [Features] item.
- Enter [Features] item till you find the [Call Forward] item.

- Press the [Call Forward] button to open call forward configuration screen and select the line to be configured with up/down navigation keys.
- Press the [Enter] button to edit the call forward settings.
- Select the call forward type with the up/down navigation keys. Click the [Enter] button to configure the call forward number and delay, if applicable.
- Enable or Disable call forward with the left/right navigation buttons against specific lines and types.
- If select 'Enable', browse the setting parameters with the up/down navigation keys and enter required information. When done, press the [Save] / [OK] button to save the changes.



**Figure 61 - Select Line for Call Forward Configuration**



**Figure 62 - Select Call Forward Type**

Unconditional	
Mode	Enabled
Tel	4355_
<div style="display: flex; justify-content: space-between; margin-top: 20px;"> <span>Delete</span> <span>123</span> <span>Save</span> <span>Back</span> </div>	

**Figure 63 - Activate Call Forward and Configure Call Forward Number**

No Answer	
Mode	Enabled
Tel	4359
Time	5_
<div style="display: flex; justify-content: space-between; margin-top: 20px;"> <span>Delete</span> <span></span> <span>Save</span> <span>Back</span> </div>	

**Figure 64 - Set Delay Time for Call Forward on No Answer**



# Chapter 6. Phone Settings

## 6.1 Adjust Audio Volume

When the device is in the default standby mode,

- Press soft-button [Menu] till you find the [Settings] item.
- Enter [Settings] item till you find the [Basic Settings] item.
- Enter [Basic Settings] item till you find [Voice Volume] item.
- Enter [Voice Volume] item and you will find [Handset Volume], [Handsfree Volume] and [Headset Volume] item.
- Enter [Handset Volume] or [Handsfree Volume] or [Headset Volume] item, press the Left/Right navigation keys to adjust the audio volume for different mode.
- Save the adjustment by pressing [OK] or [Save] when done.

## 6.2 Set Ring Tone Volume and Type

When the device is in the default standby mode,

- Press soft-button [Menu] till you find the [Settings] item.
- Enter [Settings] item till you find the [Basic Settings] item.
- Enter [Basic Settings] item till you find [Ring Settings] item.
- Enter [Ring Settings] item and you will find [Ring Volume] and [Ring Type] item.
  - Enter [Ring Volume] item and you find [Headset Volume] and [Handsfree Volume] item.
    - ◆ Enter [Headset Volume] or [Handsfree Volume] item, press the left/right navigation key to adjust the ring volume.
    - ◆ Save the adjustment by pressing [OK] when done.
  - Enter [Ring Type] item, press the left/right navigation keys to change the ring type.
    - ◆ Save the adjustment by pressing [OK] when done.

## 6.3 Adjust LCD Contrast

When the device is in the default standby mode,

- Press soft-button [Menu] till you find the [Settings] item.
- Enter [Settings] item till you find the [Basic Settings] item.
- Enter [Basic Settings] item till you find [Screen Settings] item.
- Enter [Basic Settings] item till you find [Contrast] item.

- Enter [Contrast] item, press the left/right navigation keys to adjust the LCD contrast.
- Save the adjustment by pressing [OK] or [Save] when done.

## 6.4 Set Device Time/Date

When the device is in the default standby mode,

- Press soft-button [Menu] till you find the [Settings] item.
- Enter [Settings] item till you find the [Basic Settings] item.
- Enter [Basic Settings] item till you find [Time & Date] item.
- Enter [Time & Date] item, use the up/down navigation keys to edit the time/date parameters and save the settings by pressing [OK] or [Save] when done.

**Table 4 - Time Settings Parameters**

Parameters	Description
Mode	Auto/Manual Auto: Enable network time synchronization via SNTP protocol, default enabled. Manual: User can modify data manually.
SNTP Server	SNTP server address
Time Zone	Select the time zone
12-hour Clock	Display the clock in 12-hour format
Daylight Saving Time	Enable or Disable the Daylight Saving Time
Time format	Select one of the following time formats: <ul style="list-style-type: none"> <li>■ 1 JAN, MON</li> <li>■ 1 January, Monday</li> <li>■ JAN 1, MON</li> <li>■ January 1, Monday</li> <li>■ MON, 1 JAN</li> <li>■ Monday, 1 January</li> <li>■ MON, JAN 1</li> <li>■ Monday, January 1</li> <li>■ DD-MM-YY</li> <li>■ DD-MM-YYYY</li> <li>■ MM-DD-YY</li> <li>■ MM-DD-YYYY</li> <li>■ YY-MM-DD</li> </ul>

Parameters	Description
	■ YYYY-MM-DD
Date (Only Mode = Manual)	Edit the date of the device in the format of yyyy/mm/dd.
Time (Only Mode = Manual)	Edit the time of the device in the format of hh:mm:ss. Hh=00~23, mm=00~59, ss=00~59

## 6.5 Set Device Language

When the device is in the default standby mode,

- Press soft-button [Menu] till you find the [Settings] item.
- Enter [Settings] item till you find the [Basic Settings] item.
- Enter [Basic Settings] item till you find [Language] item.
- User can change the language by using the navigation keys.

## 6.6 Reboot the Device

When the device is in the default standby mode,

- Press soft-button [Menu] till you find the [Reboot System] item.
- Press the [OK] or [Enter] button, a warning message "Reboot Now?" will be prompt to user.
- Press the [Yes] or [OK] button to execute the reset command, or [No] to exit.

## 6.7 Reset to Factory Default

When the device is in the default standby mode,

- Press soft-button [Menu] till you find the [Settings] item, and press [OK] or [Enter] button.
- Enter [Advanced Settings] item, then input the device PIN (Default PIN is 123) to enter the interface.
- Enter [Reset to Default] item, then a warning message "Factory Reset, Continues?" will be prompt to user.
- Press the [Yes] or [OK] button to execute the reset command, or [No] to exit.

# Chapter 7. Web Portal

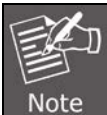
## 7.1 Web Portal Authentication

User can log in to the device web portal to manage the device or user's profile. User must provide correct username and password to be able to log in.

## 7.2 Web Call

Besides making and receiving phone calls by operating the device directly, user could also make and receive phone calls by operating the controls in the web portal.

The web call is particularly suitable for users who use headphone. User can dial out a number by clicking the [Dial] button on top of the title of the web portal page, or click a contact in the phonebook, or click a number in the call logs, to make phone call and press the [Answer] button to answer incoming call. User can click the [Hang up] button to end the call. All these operation can be done from the web portal without touching the phone.



The web call is limited to make a single call. To make or answer a second call is not allowed.

The screenshot shows the PLANET VIP-1120PT web interface. At the top right, there are buttons for 'Keep Online', 'Dial', 'Answer', and 'Hang-up', which are highlighted with a red box. Below these are navigation tabs for 'Information', 'Account', 'Configurations', 'Upgrade', 'Auto Provision', and 'Tools'. A left sidebar contains a menu with options: 'System', 'Network', 'Line', 'Phone settings', 'Phonebook', 'Call logs', and 'Function Key'. The main content area displays system information, network details, and SIP account status.

System Information		
Model:	VIP-1120PT	
Hardware:	3.1	
Software:	2.0.2.2708	
Uptime:	00 : 25 : 45	
Last uptime:	00:00:00	
MEMInfo:	ROM: 0.9/8(M) RAM: 2/16(M)	

Network		
Network mode:	Static IP	
MAC:	00:a8:59:dc:ad:1e	
IP:	172.16.0.1	
Subnet mask:	255.255.0.0	
Default gateway:	172.16.0.254	

SIP Accounts		
Line 1	N/A	Inactive
Line 2	N/A	Inactive

**Figure 65 - Web Call Controls**

The 'Dial' dialog box features a title bar with the word 'Dial' in red. It contains a 'Number:' label followed by a text input field. Below the input field are two radio button options: 'L1' (which is selected) and 'L2'. At the bottom of the dialog are 'OK' and 'Cancel' buttons.

**Figure 66 - Web Call, Entering Number and Select Line**

## 7.3 SYSTEM (Information)

User can get the following system information of the device on this page:

- Model
- Hardware Version
- Software Version
- Uptime
- Last uptime
- MEMInfo

And also summarization of network status:

- Network Mode
- MAC
- IP
- Subnet Mask
- Default Gateway

Besides, summarization of SIP account status:

- SIP User
- SIP account status (Registered/Unapplied/Trying/Timeout)

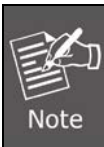
## 7.4 SYSTEM (Account)

User may change his/her web authentication password on this page.

For users with Administrators privilege, the user can also manage user accounts by adding or deleting user account and assign privilege and password to new account.

There are two types of user privilege, Administrators and Users. If a user account is created as Users privilege, this account will have limited accessibility to the device and cannot change some device settings.

The user account can be used to operate the device or access the device web portal by logging in to the device or its web. User should log in to device web portal with his/her username and web password.



The device is shipped with a default user account. **The username and password for the default account are “admin” and “123”** which are shown on the bottom side of the device.

## 7.5 SYSTEM (Configurations)

Users with Administrators privilege can export or import the device configuration on this page and reset the device to factory default.

## 7.6 SYSTEM (Upgrade)

The device supports online upgrade by periodically checking the software release version on the cloud server. Meanwhile, user can download the software and upgrade the device manually when there is trouble for the device to connect to the cloud server.

## 7.7 SYSTEM (Auto Provision)

The Auto Provision settings help IT manager or service provider to easily deploy and manage the devices in mass volume. For details on Auto Provision, please read “VIP-1120PT Administration Guide”.

## 7.8 SYSTEM (Tools)

Tools provided on this page help users to identify issues at troubleshooting. Please refer to **Chapter 9 Troubleshooting** for more details.

Besides, the device also provided the screenshot feature to user, including mail screen and sub-screen.

## 7.9 NETWORK (Basic)

User can configure the network connection type and parameters on this page.

## 7.10 NETWORK (Advanced)

The network advanced settings is often configured by IT manager to enhance the quality of service of the device. The configurations are addressed in “VIP-1120PT Administration Guide”

## 7.11 NETWORK (VPN)

User may configure a VPN connection on this page. Please refer to **8.1 VPN** for more details.

## 7.12 LINES (SIP)

The service of the line is configured on this page; choose the SIP line (SIP 1 or SIP 2) to configure. Click the drop-down arrow to adjust configuration accounting on each line.

**Table 5 - Line Configuration on Web**

Parameters	Description
<b>Basic Settings</b>	
Line Status	Display the current line status on the loading page. To get the up to date line status, user has to refresh the page manually.
Username	Enter the username of the service account.
Display Name	Enter the display name to be sent in a call request.
Authentication Name	Enter the authentication name of the service account
Authentication Password	Enter the authentication password of the service account
SIP Proxy Server Address	Enter the IP or FQDN address of the SIP proxy server
SIP Proxy Server Port	Enter the SIP proxy server port; default is 5060
Outbound Proxy Address	Enter the IP or FQDN address of outbound proxy server provided by the service provider
Outbound Proxy Port	Enter the outbound proxy port; default is 5060
Realm	Enter the SIP domain if requested by the service provider
Activate	Whether the service of the line should be activated
Codec Settings	Set the priority and availability of the codecs by adding or removing them from the list.
<b>Advanced Settings</b>	
Unconditional Call Forward	Enable unconditional call forward; all incoming calls will be forwarded to the number specified in the next field.



<b>Parameters</b>	<b>Description</b>
Unconditional Call Forward Number	Set the number of unconditional call forward.
Call Forward on Busy	Enable call forward on busy, when the phone is busy, any incoming call will be forwarded to the number specified in the next field.
Call Forward Number on Busy	Set the number of call forward on busy.
Call Forward on No Answer	Enable call forward on no answer, when an incoming call is not answered within the configured delay time, the call will be forwarded to the number specified in the next field.
Call Forward Number on No Answer	Set the number of call forward on no answer
Call Forward Delay on No Answer	Set the delay time of not answered call before being forwarded.
Enable Hotline	Enable hotline configuration; the device will dial to the specific number immediately at audio channel opened by off-hook handset or turn on hands-free speaker or headphone.
Hotline Number	Set the hotline dialing number.
Hotline Delay	Set the delay for hotline before the system automatically dialed it.
Enable Auto Answering	Enable auto-answering; the incoming calls will be answered automatically after the delay time.
Auto Answering Delay	Set the delay for incoming call before the system automatically answered it.
Subscribe For Voice Message	Enable the device to subscribe a voice message waiting notification, if enabled, the device will receive notification from the server if there is voice message waiting on the server.
Voice Message Number	Set the number for retrieving voice message.
Voice Message Subscription Period	Set the interval of voice message notification subscription.
Enable DND	Enable Do-not-disturb; any incoming call to this line will be rejected automatically.
Blocking Anonymous Call	Reject any incoming call without presenting caller ID.
Use 182 Response for Call Waiting	Set the device to use 182 response code at call waiting response.
Anonymous Call Standard	Set the standard to be used for anonymous.
Dial Without Registration	Set call out by proxy without registration.
User Agent	Set the user agent; the default is Model with Software Version.
Use Quote in Display Name	Whether to add quote in display name.

Parameters	Description
Ring Type	Set the ring tone type for the line.
Conference Type	Set the type of call conference; Local = set up call conference by the device itself; maximum supports two remote parties, Server = set up call conference by dialing to a conference room on the server.
Server Conference Number	Set the conference room number when conference type is set to be Server.
Transfer Timeout	Set the timeout of call transfer process.
Enable Long Contact	Allow more parameters in contact field per RFC 3840.
Enable Missed Call Log	If enabled, the phone will save missed calls into the call history record.
Response Single Codec	If setting enabled, the device will use single codec in response to an incoming call request.
Use Feature Code	When this setting is enabled, the features in this section will not be handled by the device itself but by the server instead. In order to control the enabling of the features, the device will send feature code to the server by dialing the number specified in each feature code field.
Enable DND	Set the feature code to dial to the server.
Disable DND	Set the feature code to dial to the server.
Unconditional Enable Call Forward	Set the feature code to dial to the server.
Unconditional Disable Call Forward	Set the feature code to dial to the server.
Enable Call Forward on Busy	Set the feature code to dial to the server.
Disable Call Forward on Busy	Set the feature code to dial to the server.
Enable Call Forward on No Answer	Set the feature code to dial to the server.
Disable Call Forward on No Answer	Set the feature code to dial to the server.
Enable Blocking Anonymous Call	Set the feature code to dial to the server.
Disable Blocking Anonymous Call	Set the feature code to dial to the server.
Specific Server Type	Set the line to collaborate with specific server type; this is to be address more in "VIP-1120PT Administration Guide".
Registration Expiration	Set the SIP expiration interval.
Use VPN	Set the line to use VPN restrict route.
Use STUN	Set the line to use STUN for NAT traversal.
Convert URI	Convert non digit and alphabet characters to %hh hex code.
DTMF Type	Set the DTMF type to be used for the line.
DTMF SIP Info Mode	Set the SIP Info mode to send '*' and '#' or '10' and '11'.

<b>Parameters</b>	<b>Description</b>
Transport Protocol	Set the line to use TCP or UDP for SIP transmission.
SIP Version	Set the SIP version.
Caller ID Header	Set the Caller ID Header.
Enable Strict Proxy	Enables the use of strict routing. When the phone receives packets from the server, it will use the source IP address, not the address in via field.
Enable user = phone	Sets user = phone in SIP messages.
Enable SCA	Enable/Disable SCA (Shared Call Appearance).
Enable BLF List	Enable/Disable BLF List.
Enable DNS SRV	Set the line to use DNS SRV which will resolve the FQDN in proxy server into a service list.
Keep Alive Type	Set the line to use dummy UDP or SIP OPTION packet to keep NAT pinhole open.
Keep Alive Interval	Set the keep alive packet transmitting interval
Sync Clock Time	Time Sync with server
Enable Session Timer	Set the line to enable call ending by session timer refreshment. The call session will be ended if there is not new session timer event update received after the timeout period.
Session Timeout	Set the session timer timeout period.
Enable Rport	Set the line to add rport to SIP headers.
Enable PRACK	Set the line to support PRACK SIP message.
Keep Authentication	Keep the authentication parameters from previous authentication.
Auto TCP	Using TCP protocol to guarantee usability of transport for SIP messages above 1500 bytes.
Enable Feature Sync	Feature Sync with server.
Enable GRUU	Supports Globally Routable User-Agent URI (GRUU).
BLF Server	The registered server will receive the subscription package from ordinary application of BLF phone. Please enter the BLF server, if the sever does not support subscription package, the registered server and subscription server will be separated.
BLF List Number	BLF List allows one BLF key to monitor the status of a group. Multiple BLF lists are supported.
SIP Encryption	Enable SIP encryption such that SIP transmission will be encrypted

Parameters	Description
SIP Encryption Key	Set the pass phrase for SIP encryption
RTP Encryption	Enable RTP encryption such that RTP transmission will be encrypted
RTP Encryption Key	Set the pass phrase for RTP encryption

## 7.13 LINES (Dial Peer)

This functionality offers you more flexible dial rule; you can refer to the following contents to know how to use this dial rule.

Parameters	Description
Phone number	<p>There are two types of matching: Full Matching or Prefix Matching. In Full matching, the entire phone number is entered and then mapped per the Dial Peer rules.</p> <p>In prefix matching, only part of the number is entered followed by T. The mapping with then take place whenever these digits are dialed. Prefix mode supports a maximum of 30 digits.</p>
<p>Note: Two different special characters are used.</p> <ul style="list-style-type: none"> <li>■ x -- Matches any single digit that is dialed.</li> <li>■ [ ] -- Specifies a range of numbers to be matched. It may be a range, a list of ranges separated by commas, or a list of digits.</li> </ul>	
Destination	Set Destination address. This is for IP direct.
Port	Set the Signal port, and the default is 5060 for SIP.
Alias	Set the Alias. This is the text to be added, replaced or deleted. It is an optional item.
<p>Note: There are four types of aliases.</p> <ul style="list-style-type: none"> <li>■ all: xxx - xxx will replace the phone number.</li> <li>■ add: xxx - xxx will be dialed before any phone number.</li> <li>■ del –The characters will be deleted from the phone number.</li> <li>■ rep: xxx - xxx will be substituted for the specified characters.</li> </ul>	
Suffix	Characters to be added at the end of the phone number. It is an optional item.
Delete Length	Set the number of characters to be deleted. For example, if this is set to 3, the phone will delete the first 3 digits of the phone number. It is an optional item.

## Examples of different alias applications

This feature allows the user to create rules to make dialing easier. There are several different options for dial rules. The examples below will show how it works.

### Example 1: Global Substitution

It seems like a shortcut to dial out. When user dials “32”, the dialed number will be replaced by “833333”. But if user dials “322”, the device will still send “322” rather than “8333332”. The replacement rules should be matched globally.

The screenshot shows the PLANET SIP configuration interface. The top navigation bar includes the PLANET logo, 'VIP-1120PT', and tabs for SIP, Dial Peer, Dial Plan, and Basic Settings. A sidebar on the left lists menu items: System, Network, Line (selected), Phone settings, Phonebook, Call logs, and Function Key. The main content area is titled 'Add Dial Peer' and contains the following fields:

- Number: 32
- Destination(Optional):
- Port(Optional):
- Alias(Optional): all:833333
- Call Mode: SIP
- Suffix(Optional):
- Deleted Length(Optional):

An 'Apply' button is located below the fields. Below the form is a 'Dial Peer Option' section with a dropdown menu, 'Delete', and 'Modify' buttons. At the bottom is a 'Dial Peer Table' with the following columns: Number, Destination(Optional), Port(Optional), Call Mode, Alias(Optional), Suffix(Optional), and Deleted Length(Optional).

**Figure 67 - Global Substitution Configuration**

## Example 2: Local Substitution

To dial a long-distance call to Taipei requires dialing area code 02 before the local phone number.

Using this feature 1 can be substituted for 02. For example, to call 62213123 would only require dialing 162213123 instead of 0262213123.

The screenshot shows the PLANET SIP configuration interface. The top navigation bar includes the PLANET logo, 'VIP-1120PT', and tabs for SIP, Dial Peer, Dial Plan, and Basic Settings. A 'Keep Online' indicator is in the top right. A left sidebar contains a menu with options: System, Network, Line, Phone settings, Phonebook, Call logs, and Function Key. The 'Line' option is selected.

The main content area is titled 'Add Dial Peer' and contains the following form fields:

- Number: 1T
- Destination(Optional):
- Port(Optional):
- Alias(Optional): rep:02
- Call Mode: SIP (dropdown menu)
- Suffix(Optional):
- Deleted Length(Optional): 1

Below the form is an 'Apply' button. Underneath is a 'Dial Peer Option' section with a dropdown menu, a 'Delete' button, and a 'Modify' button. At the bottom is a 'Dial Peer Table' header with the following columns: Number, Destination(Optional), Port(Optional), Call Mode, Alias(Optional), Suffix(Optional), and Deleted Length(Optional).

**Figure 68 - Local Substitution Configuration**

### Example 3: Add Prefixes

If the dialed number starts with the fixed prefix number, the phone will send out your dialed phone number adding prefix number automatically.

For example, when users dial “9312”, the device will send out “0079312”.

The screenshot shows the PLANET SIP configuration interface. The top navigation bar includes the PLANET logo, 'VIP-1120PT', and a 'Keep Online' status indicator. Below the navigation bar are tabs for 'SIP', 'Dial Peer', 'Dial Plan', and 'Basic Settings'. The left sidebar contains a menu with options: System, Network, Line (selected), Phone settings, Phonebook, Call logs, and Function Key. The main content area is titled 'Add Dial Peer' and contains the following fields:

- Number: 9T
- Destination(Optional):
- Port(Optional):
- Alias(Optional): add:007
- Call Mode: SIP (dropdown menu)
- Suffix(Optional):
- Deleted Length(Optional):

An 'Apply' button is located below the fields. Below the form is a 'Dial Peer Option' section with a dropdown menu, a 'Delete' button, and a 'Modify' button. At the bottom, there is a 'Dial Peer Table' header with columns: Number, Destination(Optional), Port(Optional), Call Mode, Alias(Optional), Suffix(Optional), and Deleted Length(Optional).

**Figure 69 - Add Prefixes Configuration**

## Example 4: Add Suffixes

If the dialed number ends with the fixed suffix number, the phone will send out your dialed phone number adding suffix number automatically.

For example, when users dial “1383322”, the device will send out “13833220088” .

The screenshot shows the PLANET SIP configuration interface. The top navigation bar includes the PLANET logo, 'VIP-1120PT', and a 'Keep Online' status indicator. Below the navigation bar are tabs for 'SIP', 'Dial Peer', 'Dial Plan', and 'Basic Settings'. The left sidebar contains a menu with options: System, Network, Line (selected), Phone settings, Phonebook, Call logs, and Function Key. The main content area is titled 'Add Dial Peer' and contains the following form fields:

- Number: 138T
- Destination(Optional):
- Port(Optional):
- Alias(Optional):
- Call Mode: SIP (dropdown menu)
- Suffix(Optional): 0088
- Deleted Length(Optional):

Below the form is an 'Apply' button. Underneath is a 'Dial Peer Option' section with a dropdown menu, a 'Delete' button, and a 'Modify' button. At the bottom is a 'Dial Peer Table' with the following columns: Number, Destination(Optional), Port(Optional), Call Mode, Alias(Optional), Suffix(Optional), and Deleted Length(Optional).

**Figure 70 - Add Suffixes Configuration**



### Example 5: Deletion

If the dialed number ends with the fixed prefix number, the phone will send out your dialed phone number deleting prefix number automatically.

For example, when users dial “98322”, the device will send out “8322”

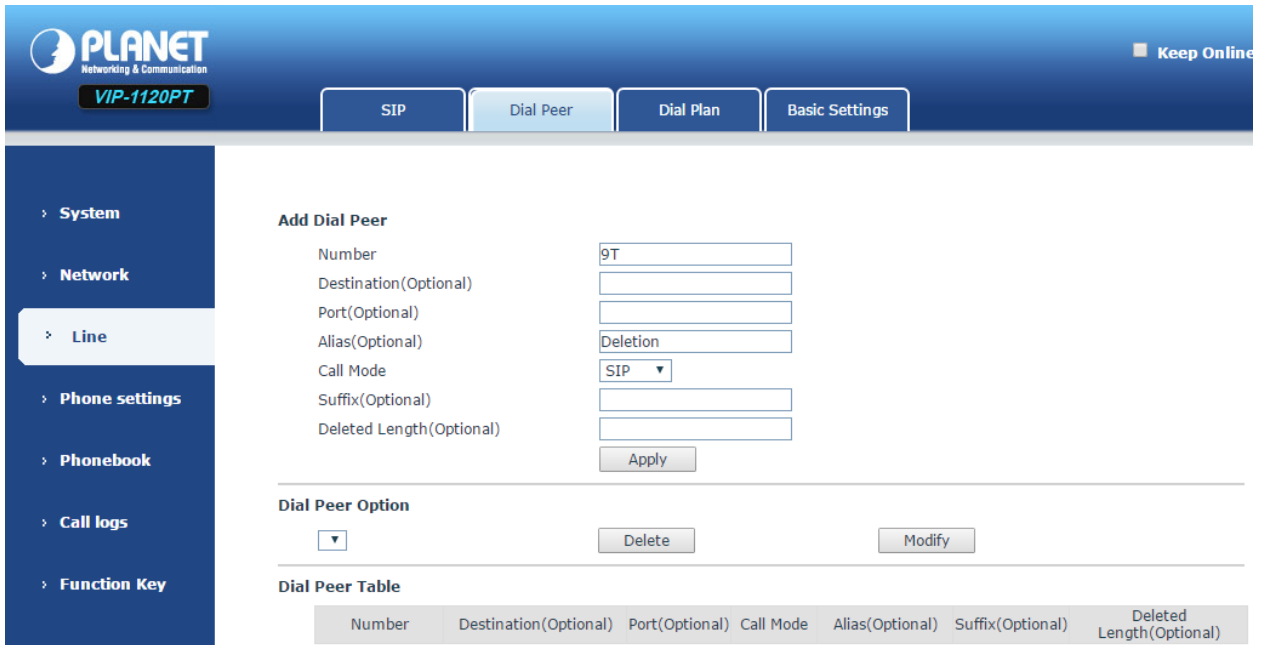


Figure 71 - Deletion Configuration

## 7.14 LINES (Dial Plan)

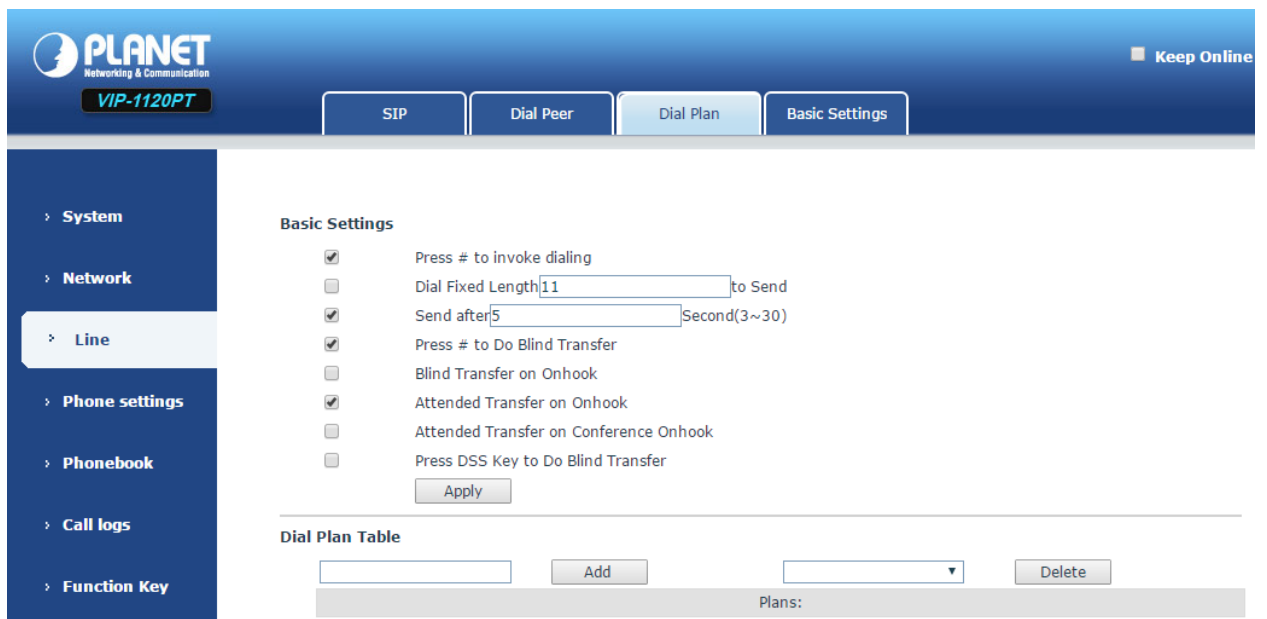


Figure 72 - Dial Plan Configuration

### The device supports 7 dialing modes:

- Press # to Send -- Dial the desired number, and press # to send it to the server.
- Dial Fixed Length -- Configure the fixed length to dial out
- Send after seconds -- Number will be sent to the server after the specified time.
- Press # to Do Blind Transfer -- Press # after entering the target number for the transfer. The phone will transfer the current call to the third party.
- Blind Transfer on Onhook -- Hang up after entering the target number for the transfer. The phone will transfer the current call to the third party.
- Attended Transfer on Onhook -- Hang up after the third party answers. The phone will transfer the current call to the third party.
- Attended Transfer on Conference Onhook -- Hang up during a 3-way conference call, the other two ways will make a call.
- Press DSS Key to Do Blind Transfer -- When user is in the 'XFER' screen, user can fulfill Blind Transfer by pressing the DSS key.

## 7.15 LINES (Global Settings)

Configure global settings for lines,

**Table 6 - Global Settings for Lines on Web**

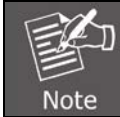
Parameters	Description
<b>SIP Settings</b>	
Local SIP Port	Set the local SIP port used to send/receive SIP messages.
Registration Failure Retry Interval	Set the retry interval of SIP REGISTRATION when registration failed.
<b>STUN Settings</b>	
Server Address	Set the STUN server address.
Server Port	Set the STUN server port; default is 3478.
Binding Period	Set the STUN binding period which can be used to keep the NAT pinhole open.
SIP Waiting Time	Set the timeout of STUN binding before sending SIP messages.
TLS Certification File	Upload or delete the TLS certification file used for encrypted SIP transmission.

## 7.16 PHONE (Features)

Configure the phone features and common Settings:


**Table 7 - Common Phone Feature Settings on Web**

Parameters	Description
Enable Phone DND	Configure the Phone DND. If enable Phone DND, the phone rejects any incoming call; the caller will automatically be prompted to hang up.
Ban Outgoing	If you select Ban Outgoing and enable it, and you cannot dial out any number.
Enable Call Transfer	Enable Call Transfer by selecting it.
Semi-Attended Transfer	Enable Semi-Attended Transfer by selecting it.
Enable 3-Way Conference	Enable 3-way conference by selecting it.
Enable Auto Hand Down	The phone will hang up and return to the idle automatically in hands-free mode.
Auto Hand Down Time	Specify Auto hand down time, the phone will hang up and return to the idle automatically after Auto Hand down time in hands-free mode, and play dial tone Auto hand down time in handset mode.
Enable Auto Redial	Enable Auto Redial by selecting it, then the phone reminds whether redial, when the dialed line is busy or rejects.
Auto Redial Interval	Configure the Auto redial interval.
Auto Redial Times	Configure the Auto redial times.
Enable Call Waiting	Enable this setting to allow user to take second incoming call during an established call. Default enabled.
Enable Call Waiting Tone	Turn off this feature, and you will not hear a 'beep' sound in talking mode when there is another incoming call.
Enable Call Completion	Enable Call Completion by selecting it; if the dialed line is busy, the sip server will inspect the dialed line status at intervals. If the dialed line is idle, the server will send notification message to inform the caller whether to redial.
Enable Pre-Dial	To disable this feature, enter the number to open audio channel automatically. To enable the feature, enter the number without opening audio channel.
Hide DTMF	Configure the hide DTMF mode.
Auto Headset	Enable this feature; headset is plugged in the phone. User presses 'answer' key or line key to answer a call with the headset automatically.

Parameters	Description
Ring From Headset	Enable Ring From Handset by selecting it; the phone plays ring tone from handset.
Enable Intercom	When intercom is enabled, the device will accept the incoming call request with a SIP header of Alert-Info instruction to automatically answer the call after specific delay.
Enable Intercom Mute	Enable mute mode during the intercom call
Enable Intercom Tone	If the incoming call is intercom call, the phone plays the intercom tone
Enable Intercom Barge	Enable Intercom Barge by selecting it; the phone auto answers the intercom call during a call. If the current call is intercom call, the phone will reject the second intercom call.
Emergency Call Number	Configure the Emergency Call Number. Despite the keyboard is locked, you can dial the emergency call number.
Enable Password Dial	Enable Password Dial by selecting it. When number entered is beginning with the password prefix, the following N numbers after the password prefix will be hidden as *, N stand for the value which you enter in the Password Length field. For example, you set the password prefix is 3, enter the Password Length is 2, then you enter the number 34567, it will display 3**67 on the phone.
Encryption Number Length	Configure the Encryption Number length.
Password Dial Prefix	Configure the prefix of the password call number.
Restrict Active URI Source IP	Set the device to accept Active URI command from specific IP address.  This feature is usually used for device management and will be described in "VIP-1120PT Administration Guide".
Push XML Server	Configure the Push XML Server; when phone receives request, it will determine whether to display corresponding content on the phone which sent by the specified server or not.
Allow IP Call	If enabled, user can dial out with IP address.
Enable Multi Line	Enable phone to make calls for 10 lines max, or disable for 2 lines max.
Enable Default Line	If enabled, user can assign default SIP line for dialing out rather than SIP1.
Enable Auto Switch Line	Enable phone to select an available SIP line as default automatically.
DND Response Code	Set the SIP response code on call rejection on DND.
Busy Response Code	Set the SIP response code on line busy.
Reject Response Code	Set the SIP response code on call rejection.
Play Talking DTMF Tone	Play DTMF tone on the device when user pressed a phone digits during

Parameters	Description
	taking; default enabled.
Play Dialing DTMF Tone	Play DTMF tone on the device when user presses a phone digits at dialing; default enabled.
Caller ID Display Priority	Change caller ID display priority. The default priority is "Phonebook" > "SIP Display Name" > "SIP URI". User may select one of the options to change the desired caller ID display priority.
Display Num With Name	Allow user to determine the caller-id display method. If it is checked, the caller-id will display number with name. If the value is unchecked, the caller-id will abide by CID Priority..

### Action URL

 <b>Note</b>	Action URL is used for device event submitting with IPPBX system. The detail is addressed in the "VIP-1120PT Administration Guide".
--	---

### Restrict Outgoing Call

The user with Administrators privilege can set the rule to restrict some numbers from dialing out. This setting is device-wide and applies to every user of the device.

User can add restricted number by entering the number in the edit box and click the "Add" button. To remove a number from the restriction list, select the number from the dropdown box and click the "Delete" button to remove it.

## 7.17 PHONE (Audio)

Change the audio settings:

**Table 8 - Audio Settings on Web**

Parameters	Description
First Codec	The first preferential DSP codec:G.711A/U,G.722,G.723,G.729,G.726-32, ILBC,AMR,AMR-WB
Second Codec	The second preferential DSP codec: G.711A/U,G.722,G.723,G.729,G.726-32, ILBC,AMR,AMR-WB,NONE
Third Codec	The third preferential DSP codec:

Parameters	Description
	G.711A/U,G.722,G.723,G.729,G.726-32 , ILBC,AMR,AMR-WB,NONE
Fourth Codec	The forth preferential DSP codec: G.711A/U,G.722,G.723,G.729,G.726-32 , ILBC,AMR,AMR-WB,NONE
Fifth Codec	The fifth preferential DSP codec: G.711A/U,G.722,G.723,G.729,G.726-32, ILBC,AMR,AMR-WB,NONE
Sixth Codec	The sixth preferential DSP codec: G.711A/U,G.722,G.723,G.729,G.726-32, ILBC,AMR,AMR-WB,NONE
Onhook Time	Configure the least reflection time of Hand down, the default is 200ms.
Tone Standard	Set the country standard of call progress tones, including dial tone, busy tone, ring-back tone, etc.
Default Ring Type	Set the default ring type. If the caller ID of an incoming call was not configured with specific ring type, the default ring will be used.
Handset Volume	Set the Handset volume; the value must be 1~9.
Headset Volume	Set the Headset volume; the value must be 1~9.
Headset Ring Volume	Set the ring volume in the headset; the value must be 1~9.
Speakerphone Volume	Set the speakerphone volume; the value must be 1~9.
Speakerphone Ring Volume	Set the ring volume in the speakerphone; the value must be 1~9.
Headset Volume Offset	This is to adjust the base volume of the headset. Please note when set the volume at the maximum level it may create noise and decrease the echo canceller.
Headset Mic Offset	This is to adjust the base volume of the headset Mic.
G.729AB Payload Length	Set G729 Payload Length.
G.723.1 Bit Rate	5.3kb/s or 6.3kb/s is available.
G.722 Timestamps	160/20ms or 320/20ms is available.
DTMF Payload Type	Enter the DTMF payload type; the value must be 96~127.
Enable VAD	Enable Voice Activity Detection. When enabled, the device will suppresses the audio transmission with artificial comfort noise signal to save the bandwidth.
Enable MWI Tone	The phone will play MWI tone when a new MWI comes.
Auto Answer By Headset	When this item is checked, the device will auto-answer phone calls by

Parameters	Description
	headset if the auto-answer or intercom is enabled.

## 7.18 PHONE (MCAST)

This feature allows user to make some kind of broadcast call to people who are in multicast group. User can configure a multicast DSS Key on the phone, which allows user to send a Real-time Transport Protocol (RTP) stream to the pre-configured multicast address(es) without involving SIP signaling. You can also configure the phone to receive an RTP stream from pre-configured multicast listening address(es) without involving SIP signaling. You can specify up to 10 multicast listening addresses.

**Table 9 - MCAST Parameters on Web**

Parameters	Description
Normal Call Priority	Define the priority of the active call; 1 is the highest priority, 10 is the lowest.
Enable Page Priority	The voice call in progress shall take precedence over all incoming paging calls.
Name	Multicast server name
Host: port	Multicast server's multicast IP address and port.

## 7.19 PHONE (Time/Date)

User can configure the device time settings on this page.

**Table 10 - Time/Date Setting Parameters on Web**

Parameters	Description
<b>Network Time Server Settings</b>	
Time Synchronized via SNTP	Enable time-sync through SNTP protocol.
Time Synchronized via DHCP	Enable time-sync through DHCP protocol.
Primary Time Server	Set primary time server address.
Secondary Time Server	Set secondary time server address; when primary server is not reachable, the device will try to connect to secondary time server to get time synchronization.
Time Zone	Select the time zone.
Resync Period	Time of re-synchronization with time server.
12-hour Clock	Set the time display in 12-hour mode.

Parameters	Description
Date Format	Select the time/date display format.
<b>Daylight Saving Time Settings</b>	
Location	Select the user's time zone specific area
DST Set Type	Select automatic DST according to the preset rules of DST, or the manually input rules
Offset	The DST offset time
Month Start	The DST start month
Week Start	The DST start week
Weekday Start	The DST start weekday
Hour Start	The DST start hour
Minute Start	The DST start minute
Month End	The DST end month
Week End	The DST end week
Weekday End	The DST end weekday
Hour End	The DST end hour

## 7.20 PHONE (Advanced)

User can configure the advanced configuration settings on this page.

- Screen Configuration.
  - Contrast
  - Backlight Time
- LCD Menu Password Settings.

The password is **123** by default.

- Keyboard Lock Settings.
- Configure Greeting Words

The greeting message will display on the top left corner of the LCD when the device is idle, which is limited to **16** characters. The default chars are '**PLANET PHONE**'.

## 7.21 PHONEBOOK (Contacts)

User can add, delete, or edit contacts in the phonebook on this page. User can browse the phonebook and sort it by name, phones, or filter them out by group.

To add a new contact, user should enter contact's information and press the "Add" button to add it.



To edit a contact, click on the checkbox in front of the contact. The contact information will be copied to the contact edit boxes. Press the “Modify” button after finishing editing.

To delete one or multiple contacts, check on the checkbox in front of the contacts wished to be deleted and click the “Delete” button, or click the “Clear” button by selecting any contacts to clear the phonebook.

User can also add multiple contacts into a group by selecting the group in the dropdown options in front of the “Add to Group” button at the bottom of the contact list. Select contacts by checking the checkbox and click “Add to Group” to add selected contacts to the group.

Similarly, user can select multiple users and add them to blacklist by clicking the “Add to Blacklist” button.

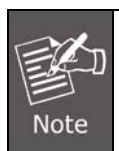
## 7.22 PHONEBOOK (Cloud Phonebook)

### Cloud Phonebook

User may configure up to 8 cloud phonebooks. Each cloud phonebook must be configured with an URL where an XML phonebook is stored. The URL may be based on HTTP/HTTPs or FTP protocol with or without authentication. If authentication is required, user must configure the username and password.

To configure a cloud phonebook, the following information should be entered:

- Phonebook name (must)
- Phonebook URL (must)
- Access username (optional)
- Access password (optional)



In regard to creating a cloud phonebook and setting up a cloud phonebook server, please refer to “VIP-1120PT Administration Guide”.

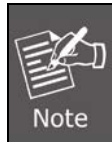
### LDAP Settings

The cloud phonebook allows user to retrieve contact list from a LDAP Server through LDAP protocols.

User must configure the LDAP Server information and Search Base to be able to use it on the device. If the LDAP server requests an authentication, user should also provide username and password.

To configure an LDAP phonebook, the following information should be entered:

- Display Title (must)
- LDAP Server Address (must)
- LDAP Server Port (must)
- Search Base (must)
- Access username (optional)
- Access password (optional)



In regard to creating an LDAP phonebook and setting up an LDAP phonebook server, please refer to “VIP-1120PT Administration Guide”.

## 7.23 PHONEBOOK (Blacklist)

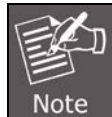
By adding a number to the blacklist, user will no longer receive phone call from that number and it will be rejected automatically by the device until user deletes it from the blacklist.

User can add specific number to be blocked, or a prefix where any numbers matched the prefix will all be blocked.

## 7.24 PHONEBOOK (Advanced)

User may export current phonebook in xml, csv, or vcf format file and save it locally on a computer.

User can also import contacts into phonebook from an xml, csv, or vcf file.



If user repeatedly imports a same phonebook, it will create duplicated contacts in user's phonebook.

User can add new group on this page or delete an existing one. Deleting a contact group will not delete the contacts in that group.

## 7.25 CALL LOGS

User can browse complete call logs on this page, order the call logs by time, caller ID, contact name, duration, or line, and can also filter the call logs by the call log types, in, out, missed, or all.

User can save a call log into his/her phonebook or add it to the blacklist.

User can also make web call by clicking on the number of a call log.

## 7.26 FUNCTION KEY

The device provides 2 users -- define DSS Keys at most. User may configure/customize each DSS key on this webpage.

**Table 11 - DSS Key Setting Parameters on Web**

Parameters	Description
Memory Key	<p><b>BLF (NEW CALL/BXFE /AXFER):</b> It is used to prompt user the state of the subscribe extension, and it can also pick up the subscribed number, which help user monitor the state of subscribe extension (idle, ringing, a call). There are 3 types for one-touch BLF transfer method. p.s. User should enter the pick-up number for specific BLF key to fulfill the pick-up operation.</p> <p><b>Presence:</b> Compared to BLF, the Presence is also able to view whether the user is online.</p> <p>Note: You cannot subscribe the same number for BLF and Presence at the same time</p> <p><b>Speed Dial:</b> You can call the number directly which you set. This feature is convenient for you to dial the number which you frequently dialed.</p> <p><b>Intercom:</b> This feature allows the operator or the secretary to connect the phone quickly; it is widely used in office environments.</p>
Line	It can be configured as a Line Key. User is able to make a call by pressing Line Key.
Key Event	User can select a key event as a shortcut to trigger. For example, MWI, DND, Release, Headset, Hold, etc.
DTMF	It allows user to dial or edit dial number easily.
URL	Open the specific URL directly.
Multicast	Configure the multicast address and audio codec. User presses the key to initiate the multicast.

## 7.27 FUNCTION KEY (Softkey)

User can configure different functions in different screens for each softkey.

The screenshot shows the PLANET Network & Communication web interface. The top navigation bar includes the PLANET logo, a 'VIP-1120PT' badge, and a 'Keep Online' status indicator. Below the navigation bar are two tabs: 'Function Key' and 'Softkey'. A left-hand sidebar menu lists various system settings categories: System, Network, Line, Phone settings, Phonebook, Call logs, and Function Key (which is currently selected). The main content area is titled 'SoftKey Settings' and contains the following elements:

- Softkey Mode:** A dropdown menu currently set to 'More'.
- Screen:** A dropdown menu currently set to 'Call Dialer'.
- Unselected Softkeys:** A list box containing the following items: None, Call Back, Clear, In, Join, Missed, MWI, Next Line(Next), Dialed, Pause, Phonebook(Dir), Pickup, Prev Line(Prev.), Redial, and Remote XML(R-XML). Below this list are two arrow buttons: a right-pointing arrow and a left-pointing arrow.
- Selected Softkeys:** A list box containing the following items: Delete, History, Dial, and Exit. To the right of this list are two arrow buttons: an up-pointing arrow and a down-pointing arrow.
- Apply:** A button located at the bottom center of the configuration area.

**Figure 73 - Softkey Configuration**

# Chapter 8. Advanced Features

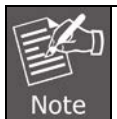
## 8.1 VPN

Virtual Private Network (VPN) is a technology to allow device to create a tunneling connection to a server and becomes part of the server's network. The network transmission of the device may be routed through the VPN server.

For some users, especially enterprise users, a VPN connection might be required to be established before activate a line registration. The device supports two VPN modes, Layer 2 Transportation Protocol (L2TP) and OpenVPN.

The VPN connection must be configured and started (or stopped) from the device web portal.

## 8.2 L2TP



The device only supports non-encrypted basic authentication and non-encrypted data tunneling. For users who need data encryption, please use OpenVPN instead.

To establish a L2TP connection, users should log in to the device web portal, open page [Network] -> [VPN]. In VPN Mode, check the "Enable VPN" option and select "L2TP", then fill in the L2TP server address, Authentication Username, and Authentication Password in the L2TP section. Press "Apply" then the device will try to connect to the L2TP server.

When the VPN connection established, the VPN IP Address should be displayed in the VPN status. There may be some delay of the connection establishment. User may need to refresh the page to update the status.

Once the VPN is configured, the device will try to connect to the VPN automatically when the device boots up every time until user disable it. Sometimes, if the VPN connection does not established immediately, user may try to reboot the device and check if VPN connection established after reboot.

## 8.3 OpenVPN

To establish an OpenVPN connection, user should get the following authentication and configuration files from the OpenVPN hosting provider and name them as follows:

OpenVPN Configuration file:	client.ovpn
CA Root Certification:	ca.crt
Client Certification:	client.crt
Client Key:	client.key

User then upload these files to the device on the web page [Network] -> [VPN], Section OpenVPN Files. Then user should check "Enable VPN" and select "OpenVPN" in VPN Mode and click "Apply" to enable OpenVPN connection.

Like an L2TP connection, the connection will be established every time when system reboots until user disables it manually.

# Chapter 9. Troubleshooting

When the device does not work properly, users may try the following methods to recover the device or gather related information.

## 9.1 Get Device System Information

Users may get the device system information by pressing [Settings] -> [Status]. The following basic information will be provided:

- Mode
- IP
- Software Version
- More...

User can select [More] item to get more information in details.

## 9.2 Upgrade to the latest software

Manufacturer will keep publishing software update to fix bugs and improve device features. The device will check for new software release on manufacturer cloud server automatically and periodically.

## 9.3 Reboot Device

Users may reboot the device from soft-menu, [Menu] -> [Reboot System], and confirm the action by [Yes]. Or, simply remove the power supply and restore it again.

## 9.4 Reset Device to Factory Default

Reset Device to Factory Default will erase all user's configuration, preference, database and profiles on the device and restore the device back to the state as factory default.






To perform a factory default reset, user should [Menu] -> [Settings] -> [Advanced settings], and then input the password to enter the interface. Then choose [Reset to Default] and press [Enter], and confirm the action by [Yes]. The device will be rebooted into a clean factory default state.

## 9.5 Network Packets Capture

Sometimes it is helpful to dump the network packets of the device for issue identification. To get the packets dump of the device, user needs to log in to the device web portal, open page [System] -> [Tools] and click [Start] in “Network Packets Capture” section. A pop-up message will be prompt to ask user to save the capture file. User then should perform relevant operations such as activate/deactivate line or making phone calls and click the [Stop] button on the web page when operation finishes. The network packets of the device during the period have been dumped to the saved file. User may examine the packets with a packet analyzer or send it to support.

## 9.6 Common Trouble Cases

**Table 12 - Trouble Cases**







Trouble Case	Solution
Device could not boot up	1. The device is powered by external power supply via power adapter or PoE switch. Please use standard power adapter provided or PoE switch met with the specification requirements and check if device is well connected to power source.
Device could not register to a service provider	1. Please check if device is well connected to the network. The network Ethernet cable should be connected to the  [Network] port, NOT the  [PC] port. If the cable is not well connected to the network icon  [WAN disconnected] will be flashing in the middle of the screen. 2. Please check if the device has an IP address. Check the system information, if the IP displays “Negotiating...”, the device does not have an IP address. Please check if the network configurations is correct.
No Audio or Poor Audio in Handset	1. Please check if Handset is connected to the correct Handset  port, NOT Headphone  port. 2. The network bandwidth and delay may be not suitable for audio call at the moment.
Poor Audio or Low Volume in Headphone	1. There are two Headphone wire sequences in the market. Please use the Headphone provided, or consults the wire sequence if you wish to use a third-party headphone. 2. The network bandwidth and delay may be not suitable for audio call at the moment.














<b>Trouble Case</b>	<b>Solution</b>
Audio is chopping at far-end in Hands-free speaker mode	This is usually due to loud volume feedback from speaker to microphone. Please lower down the speaker volume a little bit; the chopping will be gone.









## Appendix I - Icon Illustration

**Table 13 - Keypad Icons**

	Redial
	Handsfree (HF) speaker
	Phone lock = Long-pressed Key(#)
	Mute Microphone (During Call)
	Volume Down/
	Volume Up


























**Table 14 - Status Prompt and Notification Icons**

	Call out
	Call in
	Call Hold
	Network Disconnected
	Keypad Locked
	Missed calls
	SMS
	New voice message waiting
	Do-Not-Disturb activated on Phone
	Auto-answering activated
	Call forward activated

	Handsfree (HF) Mode
	Headphone (HP) Mode
	Handset (HS) Mode
	Microphone Muted
	Mixed type Input
	Lower Case
	Upper Case
	Numeric Input

## Appendix II - Text Input from Keypad

Table 15 - Look-up Table of Characters

Mode Icon	Text Mode	Key Button	Characters Of Each Press
	Numeric		1
			2
			3
			4
			5
			6
			7
			8
			9
			0
			* #(space) @ , . : / ? < > [ ] % ! & \$ ~ + -
			#
	Lower Case Alphabets		+ - * % /   @ ! :
			a b c
			d e f
			g h i
			j k l
			m n o
			p q r s
			t u v
			w x y z
			0
			* #(space) @ , . : / ? < > [ ] % ! & \$ ~ + -

Mode Icon	Text Mode	Key Button	Characters Of Each Press
		#	#
ABC	Upper Case Alphabets	1	+ - * % /   @ ! :
		2	A B C
		3	D E F
		4	G H I
		5	J K L
		6	M N O
		7	P Q R S
		8	T U V
		9	W Z Y X
		0	(space)
		*	* #(space)@ ,.:/?<>[]%! &\$~+-
		#	#
		2aB	Mixed type Input
2	2 a b c A B C		
3	3 d e f D E F		
4	4 g h I G H I		
5	5 j k l J K L		
6	6 m n o M N O		
7	7 p q r s P Q R S		
8	8 t u v T U V		
9	9 w z y x W Z Y X		
0	(space)		
*	* #(space)@ ,.:/?<>[]%! &\$~+-		
#	#		

# Appendix III - LED Definition

**Table 16 - DSS KEY LED State**

Type	LED Light	State
Line Key	Off	Line inactive
	Green On	Line ready (Registered)
	Green Blinking	Dialing / Ringing / Call holding
BLF	Green On	Subscribed number is idle.
	Red On	Subscribed number is busy.
	Red Blinking	Subscribed number is dialing.
	Off	Subscribed number is unavailable
DND	Red On	Enable DND
	Off	Disable DND
MWI	Green On	New voice message waiting
	Off	No new voice message