

**Gigabit Ethernet over VDSL2
Converter/Bridge**

VC-231G/VC-231GF/VC-234G
User's Manual

Trademarks

Copyright © PLANET Technology Corp. 2025.

Contents are subject to revision without prior notice.

PLANET is a registered trademark of PLANET Technology Corp.

All other trademarks belong to their respective owners.

Disclaimer

PLANET Technology does not warrant that the hardware will work properly in all environments and applications, and makes no warranty and representation, either implied or expressed, with respect to the quality, performance, merchantability, or fitness for a particular purpose. PLANET has made every effort to ensure that this User's Manual is accurate; PLANET disclaims liability for any inaccuracies or omissions that may have occurred.

Information in this User's Manual is subject to change without notice and does not represent a commitment on the part of PLANET. PLANET assumes no responsibility for any inaccuracies that may be contained in this User's Manual. PLANET makes no commitment to update or keep current the information in this User's Manual, and reserves the right to make improvements to this User's Manual and/or to the products described in this User's Manual, at any time without notice.

If you find information in this manual that is incorrect, misleading, or incomplete, we would appreciate your comments and suggestions.

FCC Warning

This equipment has been tested and found to comply with the limits for a Class A digital device, pursuant to Part 15 of the FCC Rules. These limits are designed to provide reasonable protection against harmful interference when the equipment is operated in a commercial environment. This equipment generates, uses, and can radiate radio frequency energy and, if not installed and used in accordance with the Instruction manual, may cause harmful interference to radio communications. Operation of this equipment in a residential area is likely to cause harmful interference in which case the user will be required to correct the interference at his own expense.

CE Mark Warning

This device is compliant with Class A of CISPR 32. In a residential environment this equipment may cause radio interference.

Energy Saving Note of the Device

This power required device does not support Standby mode operation. For energy saving, please remove the power cable to disconnect the device from the power circuit. Without removing power cable, the device will still consume power from the power source. In view of Saving the Energy and reducing the unnecessary power consumption, it is strongly suggested to remove the power connection for the device if this device is not intended to be active.

WEEE Warning



To avoid the potential effects on the environment and human health as a result of the presence of hazardous substances in electrical and electronic equipment, end users of electrical and electronic equipment should understand the meaning of the crossed-out wheeled bin symbol. Do not dispose of WEEE as unsorted municipal waste and have to collect such WEEE separately.

Revision

PLANET Gigabit Ethernet over VDSL2 Converter/Bridge User's Manual

For Models: VC-231G/VC-231GF/VC-234G

Revision: 1.6 (SEPTEMBER. 2025)

Table of Contents

1. Package Contents	5
2. Product Features.....	6
3. Hardware Introduction	8
3.1 Front Panel and LED Indicators	8
3.2 Rear Panel and DIP Switch	10
3.3 Power Information	12
4. Connecting and Using The VDSL2 Bridge	13
4.1 Point-to-Point Application -- LAN to LAN Connection.....	16
4.2 Point-to-Multipoint Application -- Connect to IP DSLAM	18
5. Product Specifications	20
6. Performance Table	22
7. Troubleshooting	25
8. FAQs	26
9. Customer Support	27
Appendix: Wall-mount and Chassis Installation.....	28

1. Package Contents

Thank you for purchasing PLANET Gigabit Ethernet over VDSL Converter/Bridge Series, VC-231G, VC-231GF and VC-234G. In the following sections, the term **“VDSL2 Bridge”** means the VC-231G Series.

Open the box of the VDSL2 Bridge and carefully unpack it. The box should contain the following items:

VDSL2 Bridge x 1		QR Code Sheet x 1
 <p>VC-231G</p>	 <p>VC-231GF</p>	 <p>VC-234G</p>
5V, 2A Power Adapter x 1	Splitter x 1 (VC-231G and VC-231GF)	RJ11 Telephone Wire x 1
		

If any of these are missing or damaged, please contact your dealer immediately; if possible, retain the carton including the original packing material, and use them again to repack the product in case there is a need to return it to us for repair.

2. Product Features

■ Physical

- VC-231G
 - 1 10/100/1000BASE-T RJ45 auto-MDI/MDI-X port
 - 1 RJ11 connector for VDSL port with VDSL connection
 - Additional splitter for POTS connection
- VC-231GF
 - 1 1000BASE-X SFP fiber-optic slot
 - 1 RJ11 connector for VDSL port with VDSL connection
 - Additional splitter for POTS connection
- VC-234G
 - 4 10/100/1000BASE-T RJ45 auto-MDI/MDI-X ports
 - 1 RJ11 built-in splitter for POTS connection
 - 1 VDSL2 RJ11 female phone jack

■ Features

- Bridge function to connect to two Ethernet LANs
 - ▶ Point-to-multipoint application: Compatible with PLANET and third-party VDSL2 IP DSLAM for last-mile solution
 - ▶ Point-to-point application: LAN to LAN extension over phone wire
- VC-231G/VC-234G: up to 200/200Mbps bandwidth (in **G.INP, Sym, 8dB** mode)
- VC-231GF: up to 150/150Mbps bandwidth (in **G.INP, Sym, 8dB** mode)
- ITU-T G.993.2 VDSL2 standard
- ITU-T G.993.5 G.Vectoring and G.INP
- DMT-based coding technology
- POTS splitter to share voice and data
- CO/CPE mode selectable via DIP switch
- Selectable target band plan (symmetric and asymmetric) and SNR margin
- Voice and data communications can be shared simultaneously based on the existing telephone wire with distance up to 1.4km.

- Supports IEEE 802.1Q VLAN tag transparency.
- VDSL2 stand-alone transceiver for simple bridge modem application
- Advantage of minimum installation time (Simply by Plug and Play)
- Supports extensive LED indicators for network diagnosis.
- Compact size and wall-mountable design
- Metal case
- Easy installation; ideal solution for space-limited locations
- The VC-231G/VC-231GF co-works with PLANET Media Chassis family (MC-700/MC-1500/MC-1500R/MC-1500R48).

3. Hardware Introduction

3.1 Front Panel and LED Indicators

■ VC-231G Front Panel

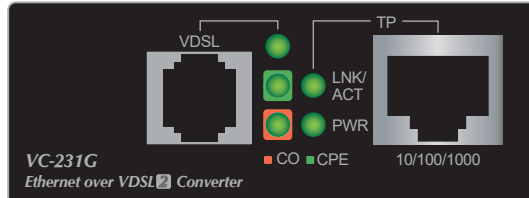

Figure 3-1-1: VC-231G Front Panel

- 10/100/1000BASE-T RJ45 connector for Ethernet
- RJ11 connector for VDSL2 for connecting to IP DSLAM or another VDSL2 Bridge
- LEDs for power, Ethernet and VDSL

■ VC-231GF Front Panel

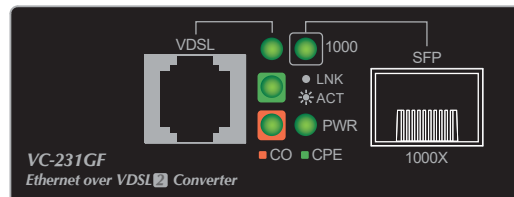

Figure 3-1-2: VC-231GF Front Panel

- 1000BASE-X SFP slot for Ethernet
- RJ11 connector for VDSL2 for connecting to IP DSLAM or another VDSL2 Bridge
- LEDs for power, Ethernet and VDSL

■ VC-234G Front Panel

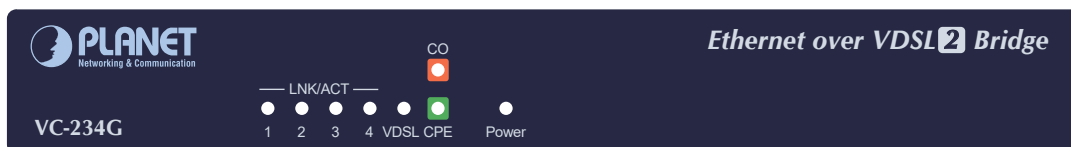

Figure 3-1-3: VC-234G Front Panel

- LEDs for power, Ethernet and VDSL

■ LED Indicators

◆ System

LED	Color	Function	
PWR	Green	Lit	Indicates that the VDSL2 Bridge has power.
		Off	Indicates that the VDSL2 Bridge has no power.

◆ VDSL

LED	Color	Function	
VDSL	Green	Lit	Indicates that the VDSL link is established.
		Fast Blink	Indicates that the VDSL link is in training status.
		Off	Indicates that the VDSL link is in idle status.
CO	Green	Lit	Indicates the VDSL2 Bridge is running in CO mode.
CPE	Green	Lit	Indicates the VDSL2 Bridge is running in CPE mode.

◆ 10/100/1000BASE-T Port for VC-231G/VC-234G

LED	Color	Function	
LNK/ ACT	Green	Lit	To indicate that the port is operating at 10/100/1000Mbps.
		Blink	To indicate that the VDSL2 Bridge is actively sending or receiving data over that port at 10/100/1000Mbps.
		Off	To indicate that the port link is down or up at 10/100/1000Mbps.

◆ 1000BASE-X SFP Port for VC-231GF

LED	Color	Function	
1000	Green	Lit	Indicates that the port is operating at 1000Mbps.
		Blink	Indicates that the VDSL2 Bridge actively sending or receiving data over that port at 1000Mbps.
		Off	Indicates that the port is link down.

3.2 Rear Panel and DIP Switch

■ VC-231G and VC-231GF Rear Panel

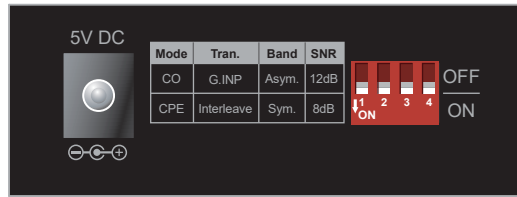

Figure 3-2-1: VC-231G and VC-231GF Rear Panel

- DIP switch
- DC jack (DC input) for power adapter

■ VC-234G Rear Panel

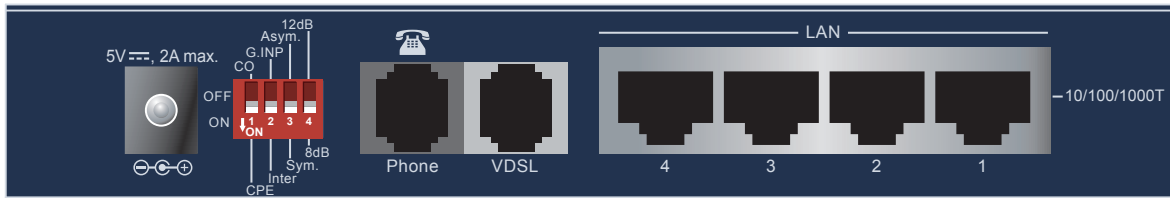

Figure 3-2-2: VC-234G Rear Panel

- Four 10/100/1000BASE-T RJ45 connectors for Ethernet
- One RJ11 connector for VDSL2 for connecting to IP DSLAM or another VDSL2 Bridge
- One RJ11 connector for telephone or PBX POTS
- DIP switch
- DC jack (DC input) for power adapter

■ DC Power Jack

The VDSL2 Bridge requires 5V DC, 2A power input, which conforms to the bundled AC adapter. Should you have the issue of power connection, please contact your local sales representative.



Note

The device is a power-required device, meaning it will not work till it is powered. If your networks should be active all the time, please consider using UPS (uninterrupted power supply) for your device. It will prevent you from network data loss or network downtime.



Note

In some areas, installing a surge suppression device may also help to protect your Ethernet over VDSL2 Bridge from being damaged by unregulated surge or current to the Ethernet over VDSL2 Bridge or the power adapter.

■ DIP Switch

The Ethernet over VDSL2 Bridge provides 4 selective transmission modes. By switching the transmission modes, you can obtain a best transmission mode to suit your phone line quality or distance of connectivity. The following is the summary table of transmission setting, bandwidth and distance extensibility tested for AWG 24 (0.5mm) twisted-pair without noise and cross talk.

	DIP-1	DIP-2	DIP-3	DIP-4
	Mode	Transmission	Band Profile	SNR Margin
OFF	CO	G.INP	Asymmetric	12dB
ON (Default)	CPE	Interleave	Symmetric	8dB

◆ DIP-1: Mode (CO/CPE)

CO (Central Office)	The Master device mode, usually the CO device, is located at the data center of ISP or enterprise to link to the backbone.
CPE (Customer Premises Equipment)	The Slave device mode, usually the CPE device, is located at branch office, home or remote side as the long reach data receiver. The CPE can be connected to the PC, IP camera or wireless access point or other network devices.



Note

When the VDSL2 Bridge operates in **CPE mode**, DIP switches 2, 3, and 4 are **out of function**.

◆ DIP-2: Transmission (G. INP and Interleave mode)

G. INP	Method of protection against bursts from other devices or lines to impact your xDSL line.
Interleave	Method of error correction used on xDSL line. Interleave requires additional latency to improve resilience to burst of error.

◆ DIP-3: Band Profile (Asymmetric/Symmetric)

Asymmetric	Asymmetric mode provides more bandwidth than the other side. This mode provides the highest bandwidth in short range.
Symmetric	With G.997 band plan supported, symmetric mode can provide almost the same rate of downstream and upstream.

◆ DIP-4: SNR (Signal Noise Ratio) Margin

When the SNR margin is selected, the system provides 12dB/8dB SNR margin for all usable loop lengths. Better channel noise protection is made with the higher SNR margin.



Note By default, the four DIP switches, set at the **"ON"** position, are operated as **"CPE"**. For operating as **"CO"**, please turn DIP 1 Switch to the **"OFF"** position. Then adjust the other DIP switches accordingly to fulfill different network application demands.



Note Please **power off** the VDSL2 Bridge before making any transmission mode adjustment.

3.3 Power Information

The central posts of the VDSL2 Bridge's power jacks measure **2.5mm** wide that require +5VDC power input. They conform to the bundled AC-DC adapter and PLANET'S media chassis. Should you have the issue of power connection, please contact your local sales representative.

Please keep the AC-DC adapter as a spare part when the VC-231G/VC-231GF is installed to a media chassis.

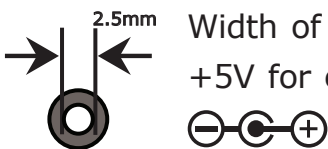

Width of DC Receptacle: 2.5mm
+5V for each slot

DC receptacle is 2.5mm wide that matches the central post, measuring 2.5mm wide, of the VDSL2 Bridge's DC jack. Do not install any improper unit.

4. Connecting and Using The VDSL2 Bridge

The Ethernet to VDSL2 Bridge does not require any software configuration. Users can immediately use any feature of this product simply by putting the plug in the receptacle and turning it on. There is some key limitation on the VDSL2 Bridge. Please check the following items:

- The device can be used for **Point-to-Point** (one **CO** device to one **CPE** device) connection or **Point-to-Multipoint** (one multi-port **CO** device to multi **CPE** devices) and allows data and voice to work on the same telephone lines.
- The VC-231G and VC-231GF provide only one RJ11 connector for VDSL2 port to build VDSL2 connection. For voice device connection, there is an additional splitter from the package of the VC-231G and VC-231GF.
- The VC-234G provides two RJ11 connectors for VDSL2 port. One is for voice device connection (like telephone) and the other one for VDSL2 network link connection.
- Depending on the quality of telephone line, the maximum distance of one VDSL2 segment is 1.4km (4593ft) with AWG 24 telephone wires. The distance could vary on the quality of telephone wires.

LAN to LAN Connection

Ethernet Telephone Network

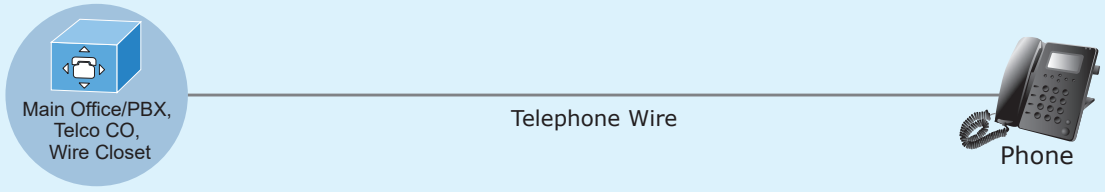

Ethernet over VDSL2 and Telephone Network

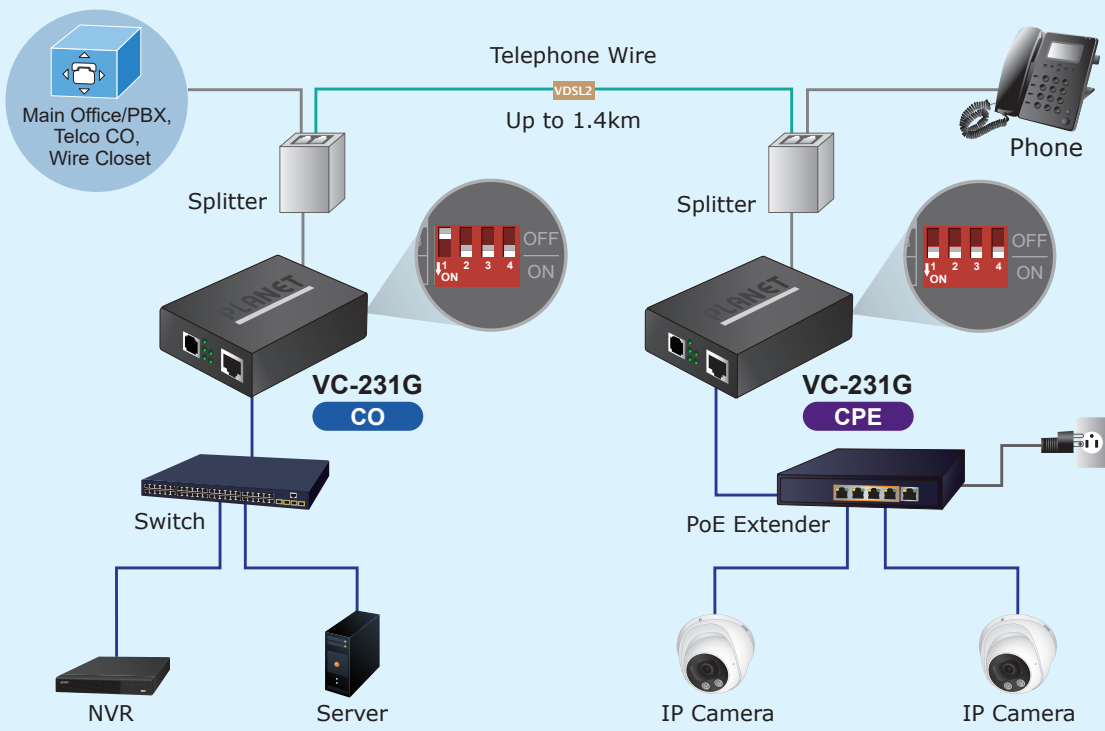

- 1000BASE-T UTP
- Telephone wire
- VDSL2

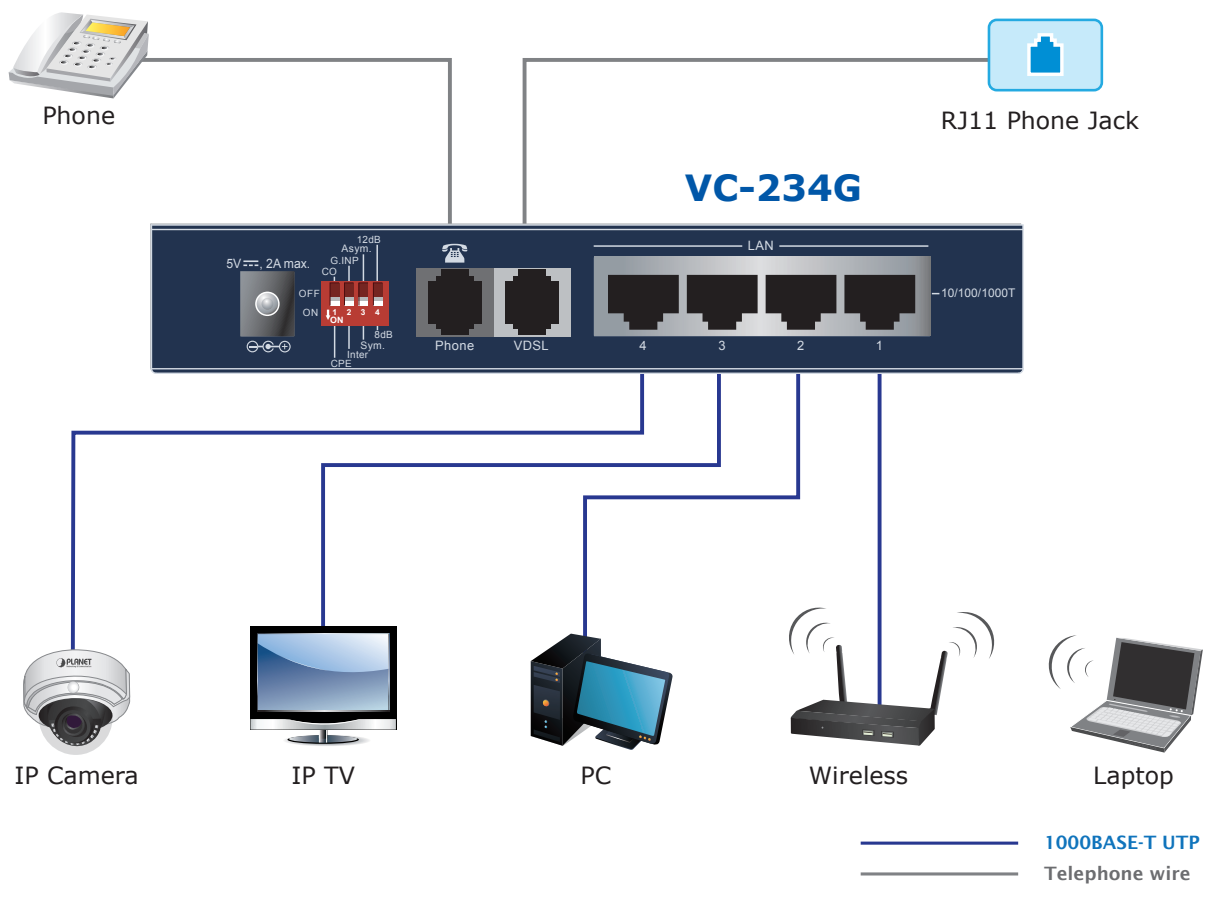
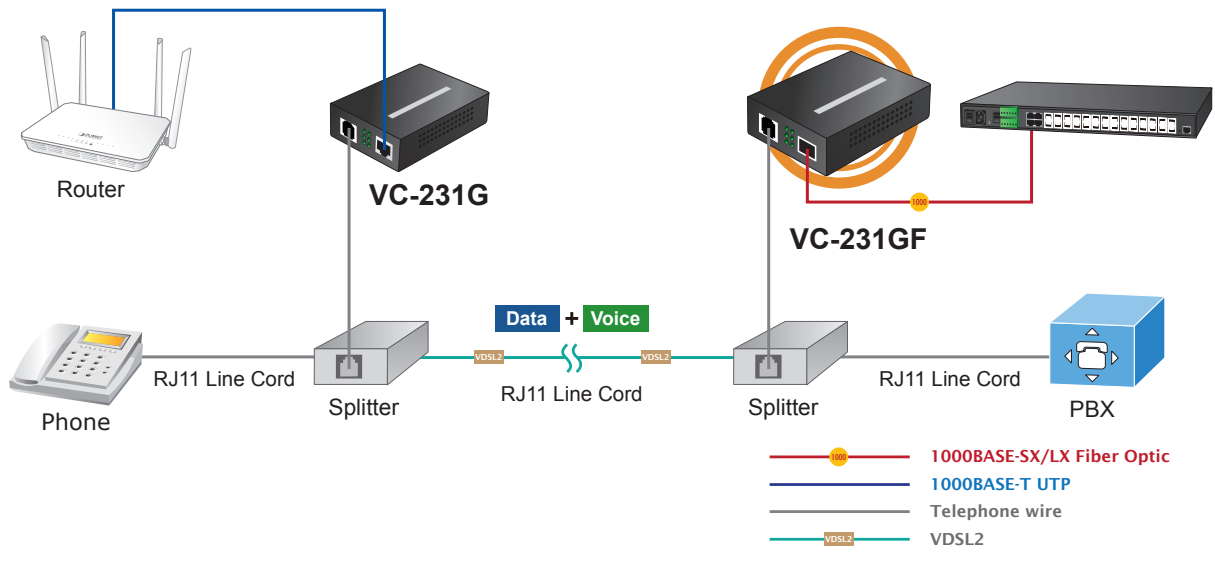

4.1 Point-to-Point Application -- LAN to LAN Connection

Two sets of the VDSL2 Bridge could be used to link two local area networks that are located in a different place. Through the normal telephone line, it could be set up as a **200/200Mbps (VC-231G/VC-234G)** or **150/150Mbps (VC-231GF)** (G.INP, Sym, 8dB) symmetric backbone, with one being VDSL2 Bridge must be Master (**CO mode**) and the other one, Slave (**CPE mode**).

LAN to LAN Connection

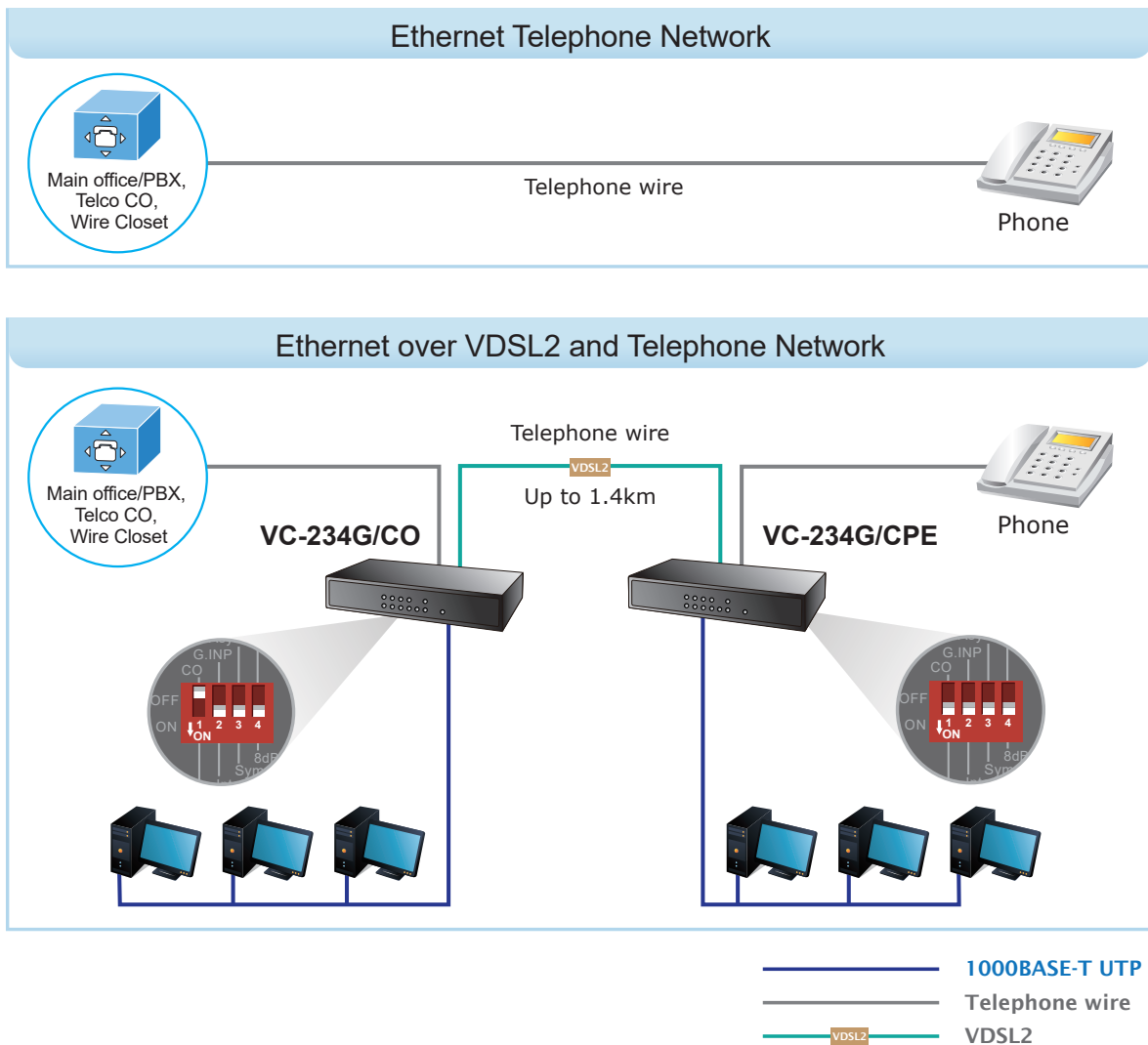

Refer to the following procedure to set up the VDSL2 Bridge LAN to LAN connection.

1. [**LAN1**] Set the VDSL2 Bridge at LAN 1 to be **CO** mode from the DIP switch.
2. [**LAN2**] Set the VDSL2 Bridge at LAN 2 to be **CPE** mode from the DIP switch.
3. Power on the VDSL2 Bridge CO and CPE at both sides by connecting its power source.
4. Power LED will illuminate.
5. Connect VDSL line from another VDSL device to RJ11 **VDSL port** of the VDSL2 Bridge.
6. **VDSL LNK LED** will blink to illuminate on both VDSL2 bridges.
7. Connect telephone to the RJ11 **Phone port** of the VDSL2 Bridge.
8. Connect the VDSL2 Bridge Ethernet **LAN port to** the other network device via regular Cat.5 UTP cable for VC-231G/VC-234G or optical fiber cable for VC-231GF.

4.2 Point-to-Multipoint Application -- Connect to IP DSLAM

To build a local Internet in apartments, hotels, campuses and hospitality environments, it requires:

- The multi-port VDSL2 IP DSLAM or VDSL2 switch (for example, PLANET VC-820M) operates as a **CO Master** and needs to be placed in the wiring center (MDF room) and connects to the telephone line system.
- On the other hand, it needs to install one or many **CPE Slaves** (the VC-231G or VC-234G VDSL Bridge) on the individual client side and connect to the multi-port Master through the telephone lines.

Multi-LAN Connection

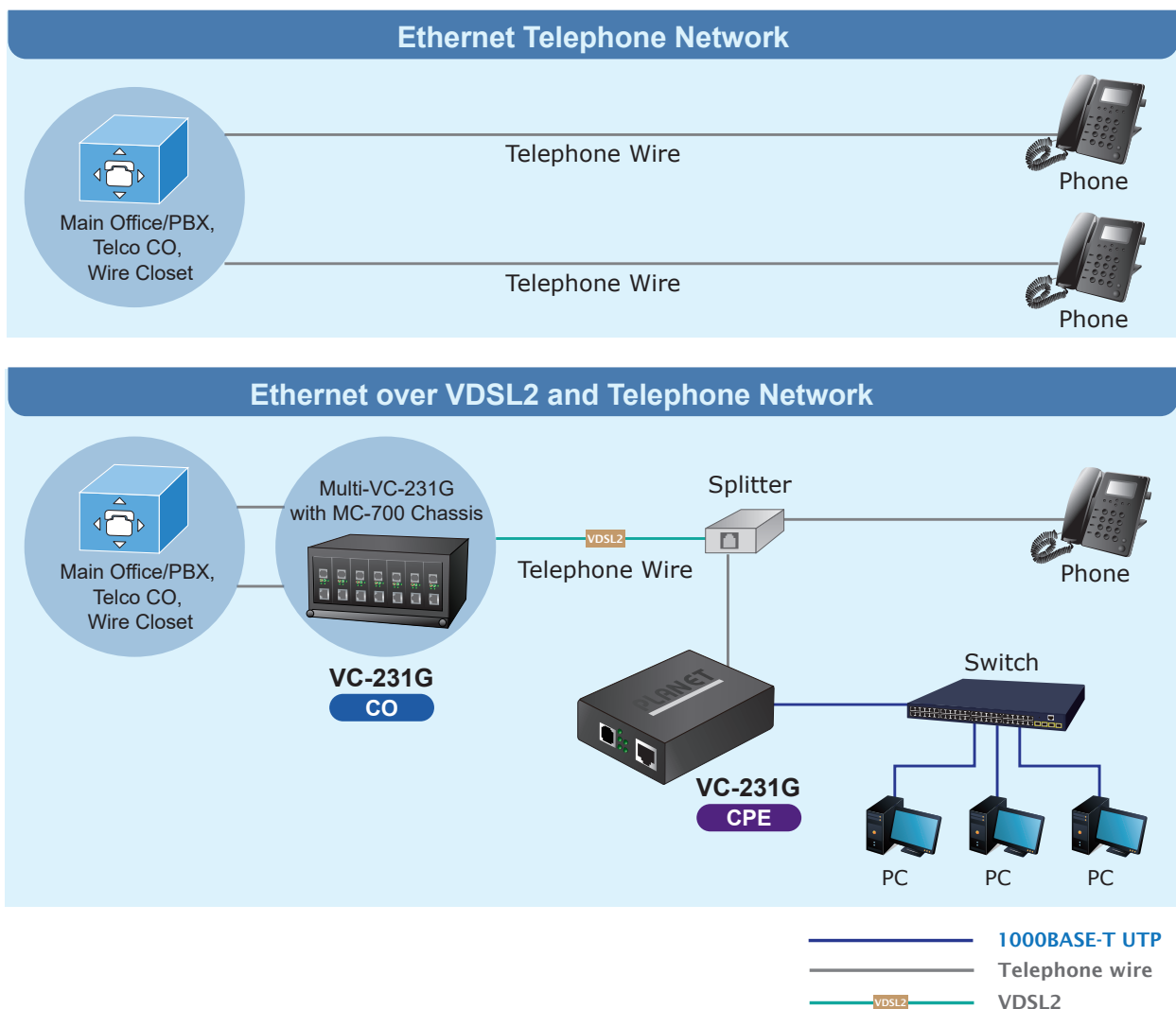

Refer to the following procedure to set up the VDSL2 Bridge to IP DSLAM connection.

1. **[Remote End]** Set the remote IP DSLAM/VDSL2 switch to **CO** mode with proper VDSL2 profile.
2. **[Local End]** Set the VDSL2 Bridge at the local end to **CPE** mode from the DIP switch.
3. Power on the VDSL2 Bridge CPEs by connecting its power source.
4. Power LED will illuminate.
5. Connect VDSL line from IP DSLAM/VDSL2 switch to RJ11 **VDSL port** of the VDSL2 Bridge.
6. **VDSL LNK LED** will blink to illuminate.
7. Connect telephone to the RJ11 **Phone port** of the VDSL2 Bridge.
8. Connect the VDSL2 Bridge Ethernet **LAN port** to other network device via regular Cat.5 UTP cable.

When deciding where to put the converter and/or prolong the operational life of the bridge, please also refer to the following points:

- It is accessible and cables can be connected easily.
- Cabling is away from sources of electrical noise such as radios, transmitters, motors, power lines and fluorescent lighting fixtures.
- Do not place objects on top of any unit or stack.
- Water or moisture cannot enter the VDSL2 Bridge.
- A minimum of 25mm away from other devices should be placed for a good ventilation.

5. Product Specifications

Product	VC-231G	VC-231GF	VC-234G
Hardware Specifications			
LAN Ports	1 10/100/1000BASE-T RJ45 auto-MDI/MDI-X port	1 1000BASE-SX/LX/BX SFP slot	4 10/100/1000BASE-T RJ45 auto-MDI/MDI-X ports
VDSL Port	1 VDSL2 RJ11 female phone jack Twisted-pair telephone wires (AWG24 or better) up to 1.4km		
Phone Port	Additional splitter for POTS connection		1 RJ11, built-in splitter for POTS connection
Dimensions (W x D x H)	97 x 70 x 26 mm		154.6 x 86.0 x 26.3 mm
Weight	196g	180g	366g
Power Requirement	DC 5V, 2A external power		
LED Indicators	1 x Power: Green 1 x 10/100/1000BASE-T LNK/ACT: Green 1 x VDSL: Green 1 x CO: Green 1 x CPE: Green	1 x Power: Green 1 x 1000BASE-X LNK/ACT: Green 1 x VDSL: Green 1 x CO: Green 1 x CPE: Green	1 x Power: Green 4 x 10/100/1000BASE-T LNK/ACT: Green 1 x VDSL: Green 1 x CO: Green 1 x CPE: Green
Housing	Metal		
DIP Switch & Functionality	DIP-1	Select CO or CPE mode.	
	DIP-2	Select G.INP or Interleaved mode.	
	DIP-3	Select Band Profile (Asymmetric or Symmetric).	
	DIP-4	Select SNR of 12dB or 8dB.	

Switch Specifications			
Switch Processing Scheme	Store-and-Forward		
Address Table	1K entries	2K entries	1K entries
Maximum Packet Size	1522 bytes		
System Specifications			
VDSL Compliance	<ul style="list-style-type: none"> ● VDSL-DMT <ul style="list-style-type: none"> - ITU-T G.993.1 VDSL - ITU-T G.997.1 - ITU-T G.993.2 VDSL2 (Profile 17a/30a/35b support) VC-231G/VC-234G - ITU-T G.993.2 VDSL2 (Profile 17a/30a Support) VC-231GF - ITU-T G.993.5 G. Vectoring - ITU-T G.998 - G.INP 		
ADSL Compliance	<ul style="list-style-type: none"> ● Capable of ADSL2/2+ standard <ul style="list-style-type: none"> - ITU G.992.3 G.dmt.bis - ITU G.992.5 G.dmt.bisplus ● Data Rate: Up to 24Mbps 		
Standards Conformance			
Standards Compliance	IEEE 802.3 Ethernet IEEE 802.3u Fast Ethernet IEEE 802.3ab Gigabit Ethernet IEEE 802.3az 1000BASE-SX/LX (VC-231GF) IEEE 802.1p Class of Service ITU-T G.993.1 VDSL ITU-T G.997.1 ITU-T G.993.2 VDSL2 (Profile 17a/30a/35b support) VC-231G/VC-234G ITU-T G.993.2 VDSL2 (Profile 17a/30a Support) VC-231GF ITU-T G.993.5 G.Vectoring & G.INP ITU-T G.998		

6. Performance Table

■ VC-231G Performance*, unit: Mbps

Distance (meter)	Interleave (Downstream/Upstream)**			
	Asymmetric		Symmetric	
	8dB	12dB	8dB	12dB
200m	260/56	267/57	175/180	165/172
400m	180/53	161/49	109/130	107/115
600m	111/48	93/46	75/93	65/82
800m	68/39	56/33	50/65	43/55
1000m	53/18	47/14	37/33	31/29
1200m	42/8	34/8	26/22	21/16
1400m	24/4	30/6	20/13	12/8
Distance (meter)	G.INP (Downstream/Upstream)			
	Asymmetric		Symmetric	
	8dB	12dB	8dB	12dB
200m	316/60	291/60	187/190	174/184
400m	185/56	161/51	108/134	99/119
600m	110/51	91/44	74/95	63/84
800m	68/38	55/34	50/66	40/55
1000m	51/18	47/15	34/35	30/30
1200m	39/10	35/8	24/22	22/18
1400m	37/6	32/2	21/13	20/10

■ VC-231GF Performance*, unit: Mbps

Distance (meter)	Interleave (Downstream/Upstream)			
	Asymmetric		Symmetric**	
	8dB	12dB	8dB	12dB
200m	190/87	178/84	147/139	135/127
400m	161/60	143/53	112/110	96/96
600m	118/36	99/32	75/73	61/59
800m	59/24	48/22	44/44	40/40
1000m	47/7	41/5	26/25	23/18
1200m	39/4	33/3	24/13	22/9
1400m	25/4	23/3	20/9	16/7
Distance (meter)	G.INP (Downstream/Upstream)			
	Asymmetric		Symmetric	
	8dB	12dB	8dB	12dB
200m	197/101	185/89	150/150	140/140
400m	168/65	148/54	117/117	97/97
600m	109/34	95/32	77/77	60/60
800m	65/20	58/14	43/43	35/35
1000m	53/7	46/6	29/28	26/21
1200m	44/4	37/3	27/15	25/11
1400m	28/4	25/3	22/10	18/8

■ **VC-234G Performance***, unit: Mbps

Distance (meter)	Interleave (Downstream/Upstream)			
	Asymmetric		Symmetric**	
	8dB	12dB	8dB	12dB
200m	285/58	264/57	182/185	170/173
400m	187/55	166/52	131/119	116/106
600m	128/53	108/50	95/89	88/78
800m	76/42	64/39	71/58	62/48
1000m	63/24	57/19	53/37	47/31
1200m	39/11	38/6	34/26	25/20
1400m	29/11	25/7	29/11	21/12
Distance (meter)	G.INP (Downstream/Upstream)			
	Asymmetric		Symmetric	
	8dB	12dB	8dB	12dB
200m	324/60	303/59	192/193	180/185
400m	246/55	211/52	135/135	119/106
600m	131/54	107/49	97/89	90/89
800m	75/45	63/41	71/56	60/50
1000m	62/25	57/20	54/40	49/33
1200m	37/12	38/9	33/25	26/21
1400m	28/12	24/9	25/16	21/12



Note

*: The actual data rate will vary on the quality of the copper wire and environmental factors.

** : Suggest use VC-231GF as CO and VC-231G or VC-234G as CPE for superior VDSL2 performance.

7. Troubleshooting

SYMPTOM:

VDSL LNK LED does not light up after wire is connected to the VDSL port.

CHECKPOINT:

1. Verify the length of the wire (not more than 1.4km) connected between the VDSL2 Bridges. Please also try to adjust the DIP switch or the VDSL2 Bridge to the other SNR mode.
2. Please note you must use one VDSL2 Bridge in CO mode and the other VDSL2 Bridge in CPE mode to make connection to each other work.

SYMPTOM:

TP LED does not light after cable is connected to the port.

CHECKPOINT:

1. Verify you are using the Cat.5 or better cable with RJ45 connector to connect to the port.
2. If your device (like LAN card) supports auto negotiation, manually set at a fixed speed of your device to solve this issue.
3. Check whether the power of the Converter/Bridge and the connected device are on or not.
4. The port's cable is firmly seated in its connectors in the switch and in the associated device.
5. The connecting cable must be good and the correct type.
6. The connecting device, including any network adapter, must be functional.

8. FAQs

Q1: What is VDSL2?

A1: VDSL2 (Very High-Bit-Rate Digital Subscriber Line 2), G.993.2, is the newest and most advanced standard of xDSL broadband wire line communications. Designed to support the wide deployment of Triple Play services such as voice, data, high definition television (HDTV) and interactive gaming, VDSL2 enables operators and carrier to gradually, flexibly, and cost efficiently upgrade the existing xDSL infrastructure.

Q2: What is SNR and what's the effect?

A2: In analog and digital communications, Signal-to-Noise Ratio, often written as SNR, is a measure of signal strength relative to background noise. The ratio is usually measured in decibels (dB).

In digital communications, the SNR will probably cause a reduction in data speed because of frequent errors that require the source (transmitting) computer or terminal to resend some packets of data. SNR measures the quality of a transmission channel over a network channel. The greater the ratio, the easier it is to identify and subsequently isolate and eliminate the source of noise.

Generally speaking, the higher SNR value gets, the better the line quality gets, but performance is lower.

Q3: What is the best distance for the VDSL2 Bridge?

A3: In order to guarantee the stability and better quality of network, we suggest the distance should not exceed 1.4 kilometers.

9. Customer Support

Thank you for purchasing PLANET products. You can browse our online FAQ resource on PLANET Website first to check if it could solve your issue. If you need more support information, please contact PLANET switch support team.

PLANET online FAQs:

<https://www.planet.com.tw/en/support/faq>

Switch support team mail address:

support@planet.com.tw

Copyright © PLANET Technology Corp. 2025.

Contents are subject to revision without prior notice.

PLANET is a registered trademark of PLANET Technology Corp.

All other trademarks belong to their respective owners.

Appendix: Wall-mount and Chassis Installation

This part describes how to install your VDSL2 Bridge and make connections to it.

Please read the following topics and perform the procedures in the order being presented.

■ Wall-mount Installation

Step 1: Please find the wall that can mount the VDSL2 Bridge.

Step 2: Screw two screws on the wall.

Step 3: Hang the VDSL2 Bridge on the screws from the wall.

Step 4: Refer to chapter 3.3 Power Information for power supply to the VDSL2 Bridge.



Note

Before mounting the device to the wall, please check the location of the electrical outlet and the length of the Ethernet cable.

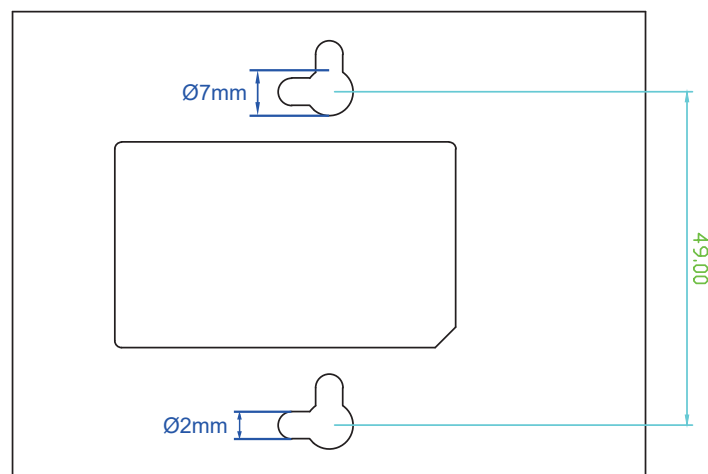

VC-231G/VC-231GF Switch Bottom Side

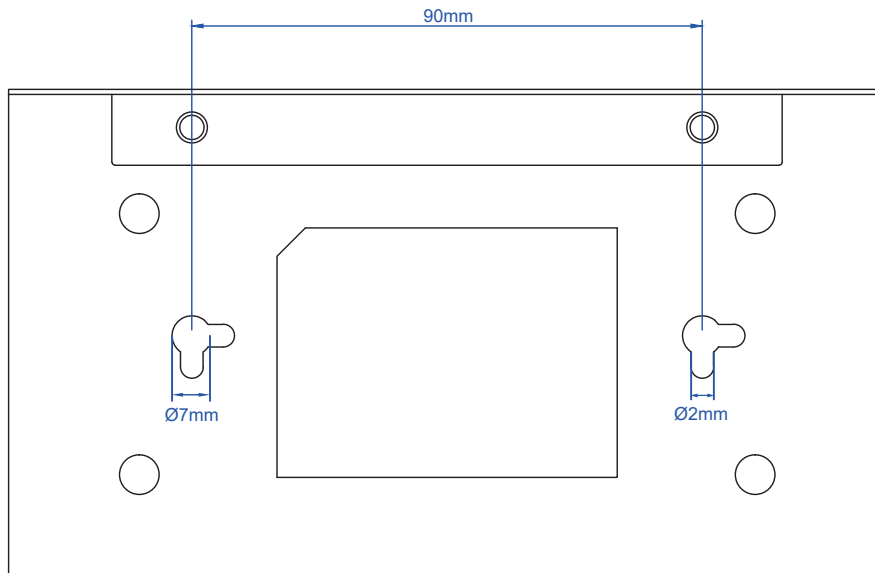
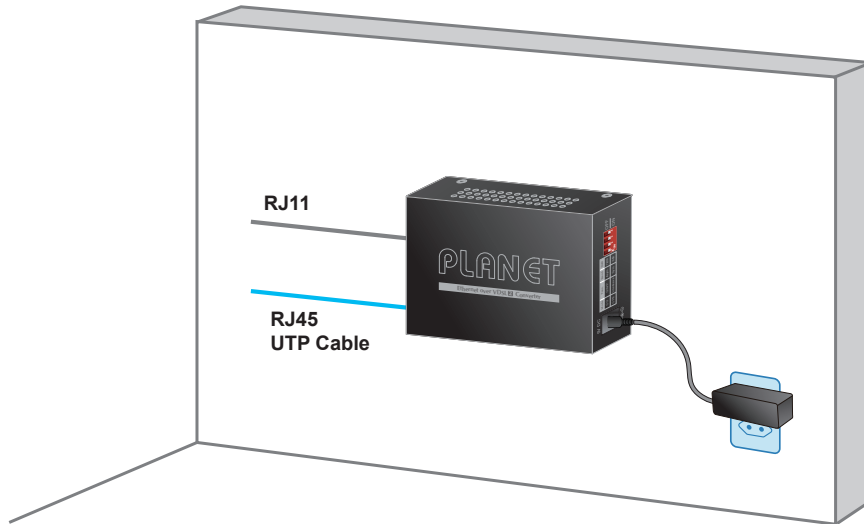

VC-234G Switch Bottom Side

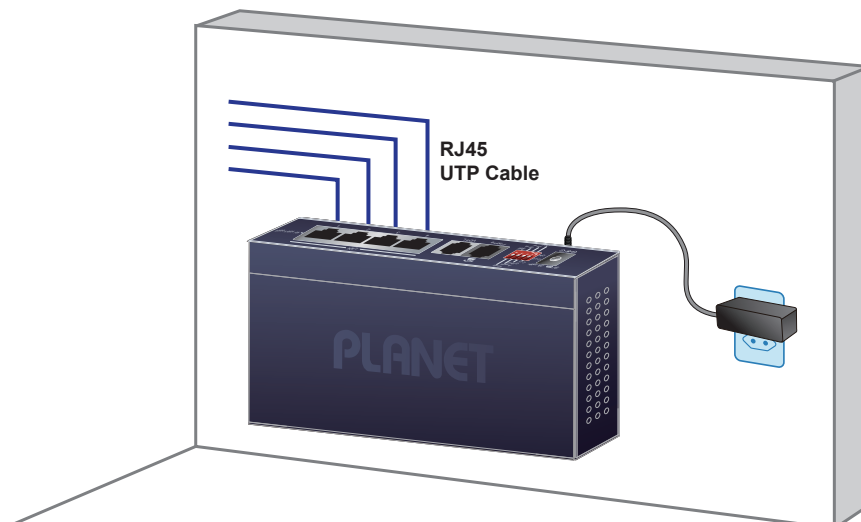

■ Chassis Installation and Rack Mounting (VC-231G and VC-231GF)

To install the Ethernet over VDSL2 Bridge in a **10-inch** or **19-inch** Converter Chassis with standard rack, follow the instructions described below.

Step 1: Place your VDSL2 Bridge on a hard flat surface, with the front panel positioned towards your front side.

Step 2: Carefully slide in the module until it is fully and firmly fitted into the slot of the converter chassis.

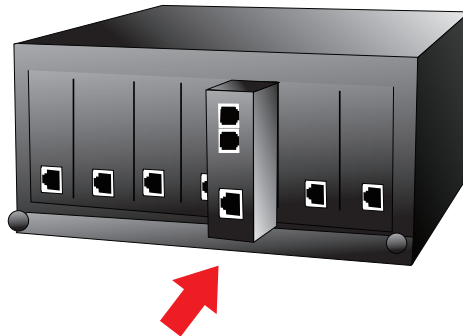

Figure Appendix 1: Insert a VDSL2 Bridge into an available slot

Step 3: Attach a rack-mount bracket to each side of the Converter Chassis with supplied screws attached to the package.

Step 4: After the brackets are attached to the Converter Chassis, use suitable screws to securely attach the brackets to the rack.

Step 5: Connect one end of the power cable to the **10-inch** or **19-inch** Converter Chassis.

Step 6: Connect the power plug of the power cable to a standard wall outlet, and then power on the **10-inch** or **19-inch** Converter Chassis. The PWR LED should be lit.



Note

Please refer to your User's Manual for setting up the device.