

## 8-Port 10/100/1000T 802.3bt PoE + 2-Port 10G SFP+ Managed Ethernet Switch



### Perfect Managed PoE++ Switch with Advanced L2/L4 Switching and Security

PLANET GS-4210-8UP2X Gigabit 802.3bt PoE++ Managed Switch features PLANET intelligent PoE functions to improve the availability of critical business applications. It provides IPv6/IPv4 dual stack management and a built-in L2/L4 Gigabit switching engine. The GS-4210-8UP2X comes with 8 10/100/1000BASE-T 802.3bt PoE++ ports and 2 10 Gigabit fiber ports, with a total power budget of 240 watts. The GS-4210-8UP2X offers a quick, safe, and cost-effective 802.3bt PoE++ network solution for small businesses and enterprises.

### Cybersecurity Network Solution to Minimize Security Risks

The cybersecurity feature included to protect the switch management in a mission-critical network virtually needs no effort and cost to install. Both SSHv2 and TLSv1.3 protocols are utilized to provide strong protection against advanced threats. The network administrator can now construct highly-secure corporate networks with considerably less time and effort than before.



### Redundant Ring, Fast Recovery for Critical Network Applications

The GS-4210-8UP2X supports redundant ring technology and features strong, rapid self-recovery capability to prevent interruptions and external intrusions. It incorporates advanced ITU-T G.8032 ERPS (Ethernet Ring Protection Switching) technology, Spanning Tree Protocol (802.1s MSTP) into customer's network to enhance system reliability and uptime in various environments.

### Physical Port

- **8 10/100/1000BASE-T ports with 95W 802.3bt PoE++** injector function (Ports 1 to 8)
- **2 10GBASE-SR/LR SFP+ slots**, backward compatible with 100/1G/2.5GBASE-X SFP transceivers (Ports XG1 to XG2)
- RJ45 to DB9 console interface for switch basic management and setup

### Switching

- Hardware-based 10/100Mbps (half/full duplex), 1000Mbps (full duplex), auto-negotiation and auto MDI/MDI-X
- IEEE 802.3x flow control for full duplex operation and back pressure for half duplex operation
- 16K MAC address table size
- 12K jumbo frame
- Automatic address learning and address aging

### Power over Ethernet

- Compliant with IEEE 802.3bt Power over Ethernet Plus Plus
- 8 ports supporting IEEE 802.3bt PoE++ with each offering up to 95 watts (Ports 1-8)
- Total PoE power budget of 240 watts
- Automatic detection of powered devices (PD)
- Built-in circuit protection to prevent power interference between ports
- Remote power feeding up to 100 meters in standard mode and 250 meters in extend mode
- Advanced PoE management capabilities:
  - Total PoE power budget control
  - Per port PoE function enable/disable
  - PoE port power feeding priority
  - Per PoE port power limitation
  - Detection of PD classification
- Intelligent PoE features
  - PD alive check
  - PoE schedule
  - Scheduled power recycling

### Layer 2 Features

- Supports VLAN
  - IEEE 802.1Q tagged VLAN
  - Provider bridging (VLAN Q-in-Q, IEEE 802.1ad) support
  - Protocol VLAN
  - Private VLAN (Protected port)
  - Management VLAN
  - GVRP

### ERPS Ring for Video Transmission Redundancy

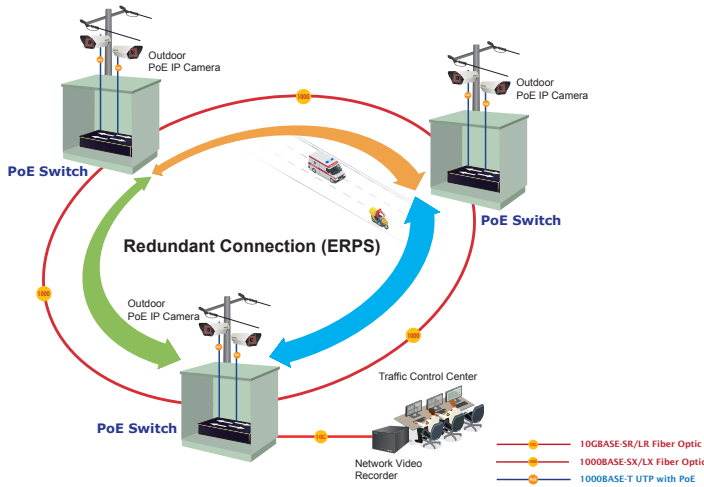

### 802.3bt PoE++ 95-watt Power over 4-pair UTP Solution

As the GS-4210-8UP2X adopts the IEEE 802.3bt PoE++ standard technology, it is capable to source up to **95 watts** of power by using all the four pairs of standard Cat5e/6 Ethernet cabling to deliver power and full-speed data to each remote PoE compliant powered device (PD). Its power capability is three times more than that of the conventional 802.3at PoE+ and it is an ideal solution for those high power consuming network PDs, such as:

- PoE PTZ speed dome cameras
- Network devices
- Thin clients
- AIO (all-in-one) touch PCs, point of sale (POS) and information kiosks
- Remote digital signage displays
- PoE lightings

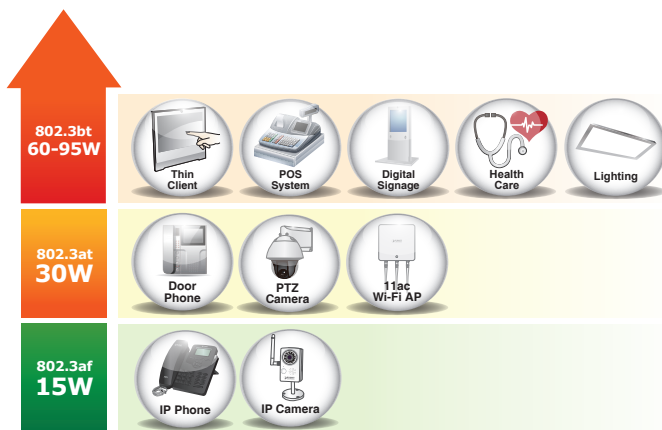

### 802.3bt PoE++ and Advanced PoE Power Output Mode Management

To meet the demand of various powered devices consuming stable PoE power, the GS-4210-8UP2X supports multi-PoE operation modes that include 95-watt 802.3bt type-4 PoE++ mode and 4-pair legacy mode to solve the incompatibility of non-standard 4-pair PoE PDs in the field.

- 95W 802.3bt PoE++ Power Output Mode
- 36W End-span 802.3at PoE Power Output Mode

PoE Watts	PoE Operation Mode	Power Output Mode
95W	802.3bt PoE++	(Pins 1, 2, 3, 6 + Pins 4, 5, 7, 8)
36W	End-span 802.3at PoE	(Pins 1, 2, 3, 6)

- Supports Spanning Tree Protocol
  - STP (Spanning Tree Protocol)
  - RSTP (Rapid Spanning Tree Protocol)
  - MSTP (Multiple Spanning Tree Protocol)
  - STP BPDU Guard, BPDU Filtering and BPDU Forwarding
- Supports Link Aggregation
  - IEEE 802.3ad Link Aggregation Control Protocol (LACP)
  - Cisco ether-channel (static trunk)
  - Maximum 8 trunk groups, up to 8 ports per trunk group
- Supports port mirror (many-to-1)
- Loop protection to avoid broadcast loops
- Supports ERPS (Ethernet Ring Protection Switching)
- Link Layer Discovery Protocol (LLDP)

### Quality of Service

- Ingress and egress rate limit per port bandwidth control
- Storm control support
  - Broadcast/Unknown unicast/Unknown multicast
- Traffic classification
  - IEEE 802.1p CoS
  - TOS/DSCP/IP precedence of IPv4/IPv6 packets
- Strict priority and Weighted Round Robin (WRR) CoS policies

### Multicast

- Supports IPv4 IGMP snooping v2 and v3
- Supports IPv6 MLD snooping v1, v2
- IGMP querier mode support
- IGMP snooping port filtering
- MLD snooping port filtering

### Security

- Authentication
  - Built-in RADIUS client to cooperate with the RADIUS servers
  - RADIUS/TACACS+ login user access authentication
  - DHCP Option 82
- Access control list
  - IPv4/IPv6 IP-based ACL
  - IPv4/IPv6 IP-based ACE
  - MAC-based ACL
  - MAC-based ACE
- MAC security
  - Static MAC
  - MAC filtering
- Port security for source MAC address entries filtering
- DHCP snooping to filter distrusted DHCP messages
- Dynamic ARP Inspection discards ARP packets with invalid MAC address to IP address binding
- IP source guard prevents IP spoofing attacks

### Built-in Unique PoE Functions for Powered Devices Management

As it is the managed PoE++ switch for surveillance, wireless and VoIP networks, the GS-4210-8UP2X features the following special PoE management functions:

- PD Alive Check
- Scheduled Power Recycling
- PoE Schedule
- PoE Usage Monitoring
- PoE Extension

### Intelligent Powered Device Alive Check

The GS-4210-8UP2X can be configured to monitor connected PD status in real time via ping action. Once the PD stops working and responding, the GS-4210-8UP2X will resume the PoE port power and bring the PD back to work. It will greatly enhance the network reliability through the PoE port resetting the PD's power source and reducing administrator management burden.

#### PD Alive Check

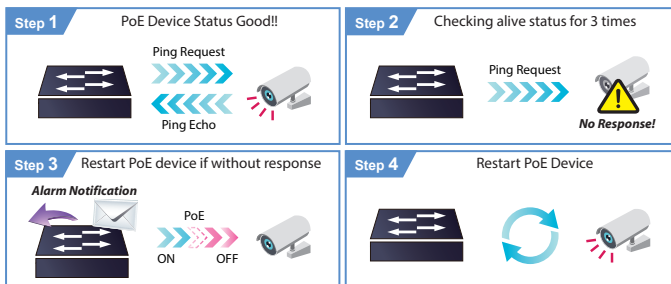

### Scheduled Power Recycling

The GS-4210-8UP2X allows each of the connected PoE IP cameras or PoE wireless access points to reboot at a specified time each week. Therefore, it will reduce the chance of IP camera or AP crash resulting from buffer overflow.

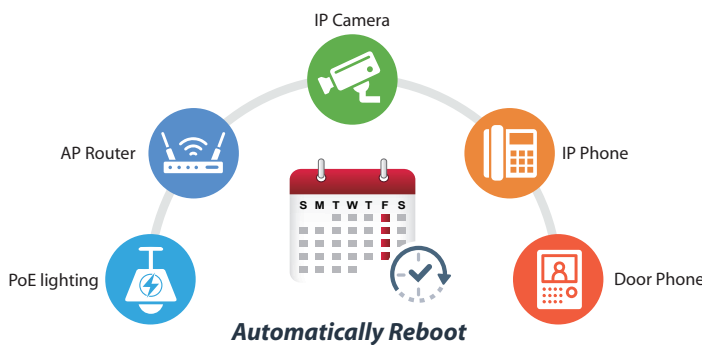

### PoE Schedule for Energy Savings

Under the trend of energy savings worldwide and contributing to environmental protection, the GS-4210-8UP2X can effectively control the power supply besides its capability of giving high watts power. The "PoE schedule" function helps you to enable or disable PoE power feeding for each PoE port during specified time intervals and it is a powerful function to help SMBs or Enterprises save power and money. It also increases security by powering off PDs that should not be in use during non-business hours.

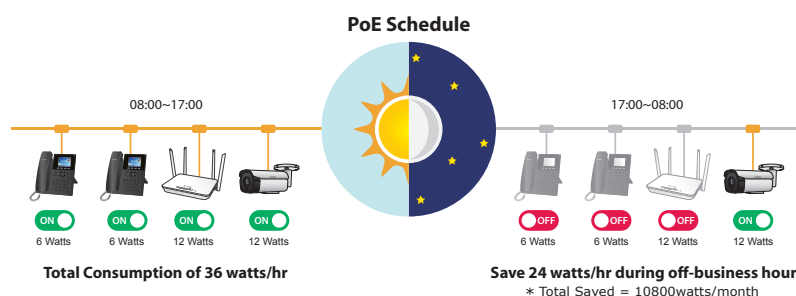

- DoS attack prevention

### Management

- IPv4 and IPv6 dual stack management
- Switch management interface
  - Web switch management
  - Console and telnet command line interface
  - SNMP v1 and v2c switch management
  - SSHv2, TLSv1.3 and SNMP v3 secure access
- SNMP Management
  - Four RMON groups (history, statistics, alarms and events)
  - SNMP trap for interface link up and link down notification
- User privilege levels control
- Built-in Trivial File Transfer Protocol (TFTP) client
- Static and DHCP for IP address assignment
- System maintenance
  - Firmware upload/download via HTTP/TFTP
  - Configuration upload/download through HTTP/TFTP
  - Dual images
  - Hardware-based reset button for system reboot or reset to factory default
- SNTP Network Time Protocol
- Network Diagnostic
  - SFP-DDM (digital diagnostic monitor)
  - Cable diagnostics
  - ICMPv4/ICMPv6 remote ping
- Link Layer Discovery Protocol (LLDP) and LLDP-MED
- Event message logging to remote syslog server
- PLANET Smart Discovery Utility for deployment management
- PLANET NMS and CloudNMS for deployment management

### PoE Usage Monitoring

Via the power usage chart in the web management interface, the GS-4210-8UP2X enables the administrator to monitor the status of the power usage of the connected PDs in real time. Thus, it greatly enhances the management efficiency of the facilities.

### 802.3at PoE+ Power and Ethernet Data Transmission Distance Extension

In the “Extend” operation mode, the GS-4210-8UP2X operates on a per-port basis at 10Mbps duplex operation but can support 50-watt PoE power output over a distance of up to 250 meters overcoming the 100m limit on Ethernet UTP cable. With this brand-new feature, the GS-4210-8UP2X provides an additional solution for 802.3at/af PoE distance extension, thus saving the cost of Ethernet cable installation.

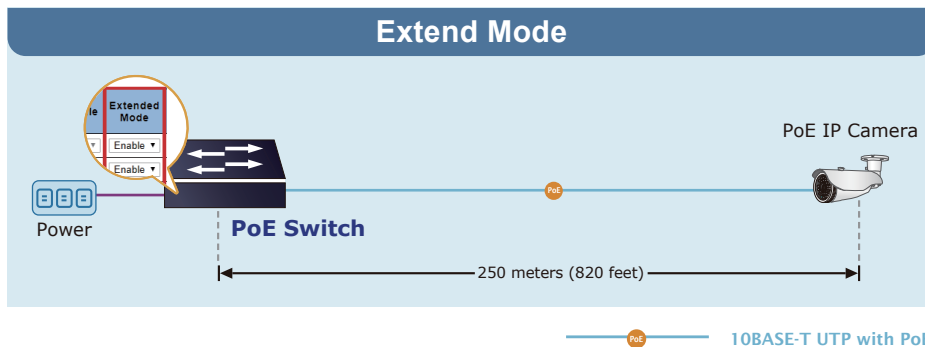

### Environment-friendly, Smart Fan Design for Silent Operation

The GS-4210-8UP2X features a rack-mount metal housing, a low noise design and an effective ventilation system. It supports the smart fan technology that automatically controls the speed of the built-in fan to reduce noise and maintain the temperature of the PoE switch for optimal power output capability. They are able to operate reliably, stably and quietly in any environment without affecting their performance.

### IPv6/IPv4 Dual Stack Management

Supporting both IPv6 and IPv4 protocols, the GS-4210-8UP2X helps the SMBs to step in the IPv6 era with the lowest investment as its network facilities need not be replaced or overhauled if the IPv6 FTTx edge network is set up.

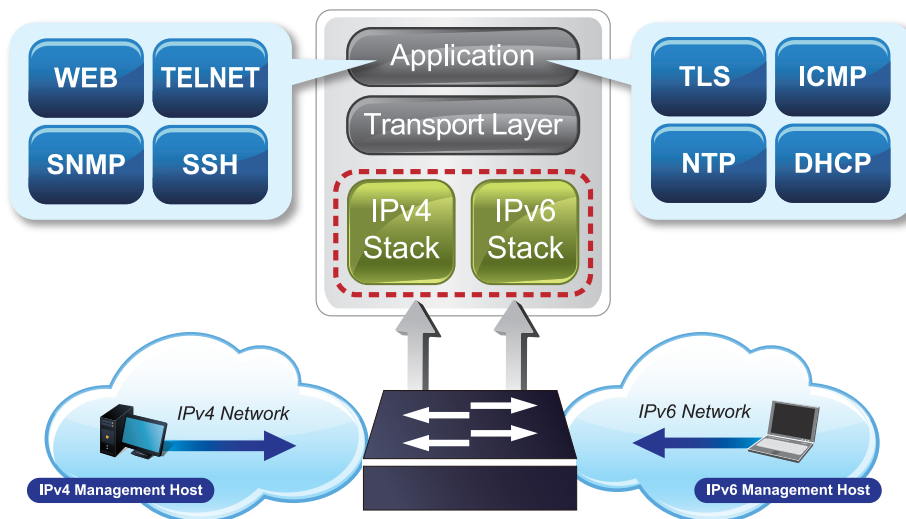

### Robust Layer 2 Features

The GS-4210-8UP2X can be programmed for advanced switch management functions such as dynamic port link aggregation, 802.1Q VLAN and **Q-in-Q VLAN**, **Multiple Spanning Tree Protocol (MSTP)**, loop and **BPDU guard**, **IGMP snooping**, and **MLD snooping**. Via the link aggregation, the GS-4210-8UP2X allows the operation of a high-speed trunk to combine with multiple ports, and supports fail-over as well. Also, the **Link Layer Discovery Protocol (LLDP)** is the Layer 2 protocol included to help discover basic information about neighboring devices on the local broadcast domain.

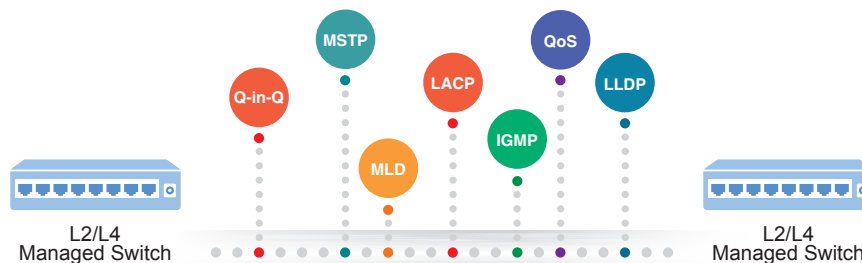

### Efficient Traffic Control

The GS-4210-8UP2X is loaded with robust QoS features and powerful traffic management to enhance services to business-class data, voice and video solutions. The functionality includes broadcast/multicast **storm control**, per port **bandwidth control**, IP DSCP QoS priority and remarking. It guarantees the best performance for VoIP and video stream transmission, and empowers the enterprises to take full advantage of the limited network resources.

### Powerful Security

The GS-4210-8UP2X offers comprehensive Layer 2 to Layer 4 Access Control List (ACL) for enforcing security to the edge. It can be used to restrict network access by denying packets based on source and destination IP address, TCP/UDP ports or defined typical network applications. Its protection mechanism also comprises 802.1x Port-based user authentication. With the private VLAN function, communication between edge ports can be prevented to ensure user privacy.

### Advanced IP Network Protection

The GS-4210-8UP2X also provides **DHCP Snooping**, **IP Source Guard** and **Dynamic ARP Inspection** functions to prevent IP snooping from attack and discard ARP packets with invalid MAC address. The network administrator can now build highly-secure corporate networks with considerably less time and effort than before.

### Efficient Management

For efficient management, the GS-4210-8UP2X is equipped with Command line, Web and SNMP management interfaces.

- With the built-in **Web-based** management interface, the GS-4210-8UP2X offers an easy-to-use, platform-independent management and configuration facility.
- For **text-based** management, it can be accessed via Telnet and the console port.
- By supporting the standard SNMP protocol, the switch can be managed via any SNMP-based management software.

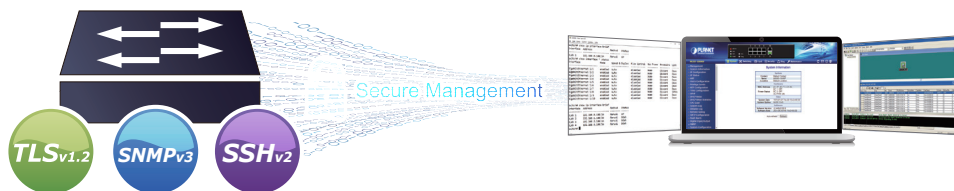

### Flexibility and Long-distance Extension Solution

The GS-4210-8UP2X can disable the PoE function to provide Gigabit TP interfaces supporting 10/100/1000BASE-T RJ45 copper for connecting surveillance network devices such as NVRs, Video Streaming Servers, or NAS systems to facilitate surveillance management. Alternatively, through its four-speed fiber SFP+ slots, it features 100BASE-FX, 1000BASE-SX/LX, 2.5G, and 10G SFP (Small Form-factor Pluggable) fiber transceivers for uplink to backbone switches and monitoring centers over long distances. The distance can be extended from 550 meters to 2 kilometers (multi-mode fiber) and up to 10/20/40/60/80/120 kilometers (single-mode fiber or WDM fiber). These models are well suited for enterprise data centers and distribution applications.

Additionally, the GS-4210-8UP2X model is available, featuring 8 10/100/1000BASE-T 802.3bt PoE++ ports and 2 10G SFP+ ports, without additional TP ports. This model is ideal for scenarios requiring extensive PoE functionality and high-speed fiber connections.

### Intelligent SFP Diagnosis Mechanism

The GS-4210-8UP2X supports **SFP-DDM (Digital Diagnostic Monitor)** function that can easily monitor real-time parameters of the SFP for network administrator, such as optical output power, optical input power, temperature, laser bias current and transceiver supply voltage.

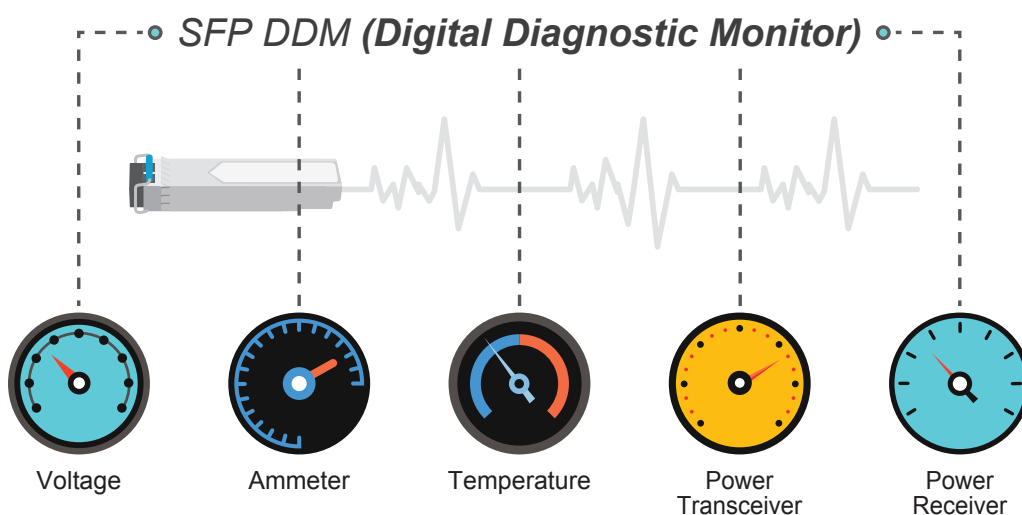

PLANET CloudNMS – Cloud-Based Universal Network Management

PLANET’s CloudNMS platform and mobile app empower IT staff to remotely manage all network devices and Powered Devices (PDs) in real time. Designed for enterprises and industries, CloudNMS minimizes the need for on-site troubleshooting by providing centralized monitoring, fault detection, and instant alerts.

With CloudNMS, businesses can manage diverse network deployments more efficiently, securely, and intelligently—all from a single cloud-based platform.



## Applications

### ITU-T G.8032 ERPS with PoE IP Surveillance System for SMBs/Workgroups

The GS-4210-8UP2X features strong rapid self-recovery capability to prevent interruptions and external intrusions. It incorporates **ITU-T G.8032 ERPS (Ethernet Ring Protection Switching)** technology into customer’s automation network to enhance system reliability and uptime. Applying the IEEE 802.3at Power over Ethernet standard, the GS-4210-8UP2X can directly connect with any IEEE 802.3at end nodes like PTZ (pan, tilt, zoom) network cameras and speed dome cameras. The GS-4210-8UP2X can easily build a power that can centrally control a wireless AP, IP camera and VoIP system for SMBs and workgroups in the enterprises with high availability network infrastructure.

### High Scalability & Best Security for Today’s Wireless Networking Solution

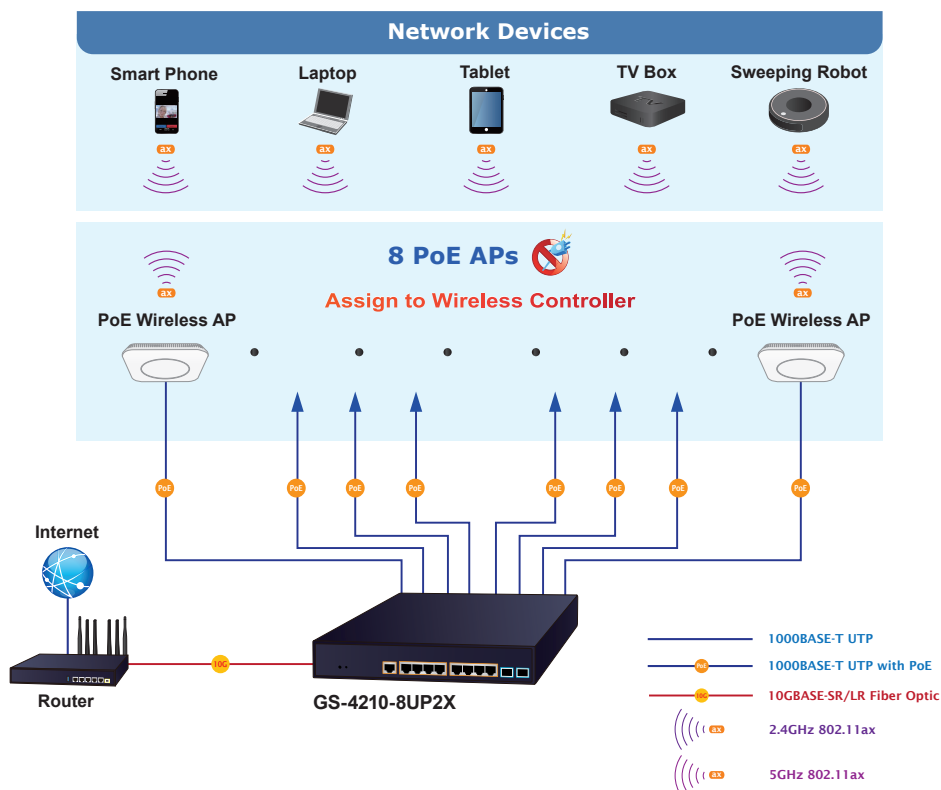

Gigabit 802.3bt PoE++ and PoE+ Network Deployment Solution

PLANET GS-4210-8UP2X can easily build an 802.3bt PoE++ networking solution on the cybersecurity system for the enterprises. For instance, it can work with the POS system and thin client to perform comprehensive security protection for today's businesses. The GS-4210-8UP2X and 802.3bt PoE++ Splitter-POE-173S, operate as a pair to provide the easiest way to power your Ethernet devices which need high power input. Receiving data and power from the GS-4210-8UP2X, the POE-173S separates digital data and power into three optional outputs (12V, 19V or 24V DC) to non-PoE devices such as laptops, Thin Client, POS System, PTZ, network cameras, PTZ speed dome, color touch-screen IP phones, multi-channel wireless LAN access points and other network devices at distance up to 100 meters.

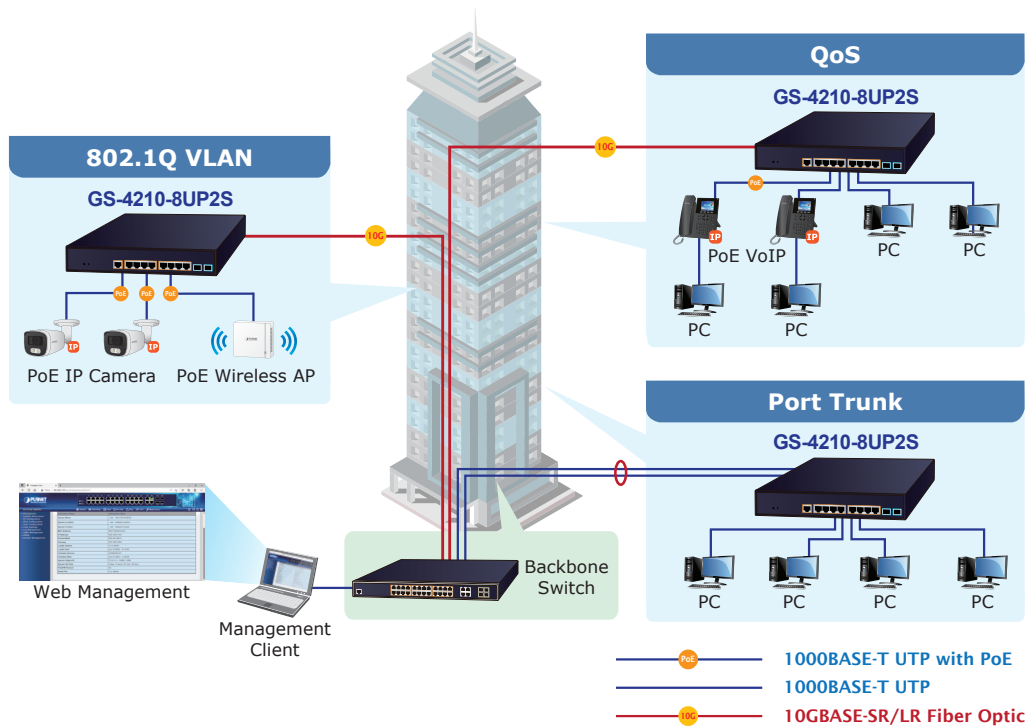

## Specifications

Product	GS-4210-8UP2X
<b>Hardware Specifications</b>	
Copper Ports	8 10/100/1000BASE-T RJ45 auto-MDI/MDI-X ports
PoE Injector Port	8 ports with 802.3bt PoE++ injector function (Ports 1 to 8)
SFP Ports	2 10GBASE-SR/LR SFP+ interfaces (Port XG1 to Port XG2) Backward compatible with 100/1G/2.5GBASE-X SFP transceivers
Console	1 x RJ45-to-RS232 serial port (115200, 8, N, 1)
Reset Button	< 5 sec: System reboot > 5 sec: Factory default
Power Requirements	AC 100~240V, 50/60Hz
Power Consumption/ Dissipation	Max. 10.7 watts/36.5BTU (Power on without any connection) Max. 269 watts/917.87BTU (Full loading)
Dimensions (W x D x H)	280 x 230 x 44mm
Weight	1885g
Installation	Rack mount
Surge Protection	Common mode 4KV, Differential mode 2KV
ESD Protection	Contact Discharge 6KV DC Air Discharge 8KV DC
Fan	1 smart fans
LED	<b>System</b> Power LED (Green) SYS LED (Green) <b>Ports</b> 10/100/1000 RJ45 Ports LNK/ACT (Green) 10G SFP+ Interface LNK/ACT (Green) PoE-in-Use (Amber)
<b>Switch Specifications</b>	
Switch Architecture	Store-and-Forward

Switch Fabric	56Gbps/non-blocking
Switch Throughput@64Bytes	41.66Mpps @64 bytes
Address Table	16K entries
Shared Data Buffer	12Mbits
Flow Control	IEEE 802.3x pause frame for full duplex
Jumbo Frame	Back pressure for half duplex
<b>Power over Ethernet</b>	
PoE Standard	IEEE 802.3bt PoE++ PSE Backward compatible with IEEE 802.3at/af PoE PSE
PoE Power Supply Type	802.3bt : End-span+Mid-span 802.3at : End-span
PoE Power Output	Port 1 to 8 – 95W (max.)
Power Pin Assignment	802.3bt/UPoE: 1/2(-), 3/6(+), 4/5(+), 7/8(-) 802.3at PoE: End-span: 1/2(-), 3/6(+)
PoE Power Budget	240 watts (max)
Number of 95W 802.3bt Type-4 PDs	2
Number of 60W 802.3bt Type-3 PDs	4
Number of 802.3at PDs	8
<b>PoE Management Functions</b>	
Enhanced PoE Mode	System PoE Admin Mode Consumption Mode/Allocation Mode Temperature Threshold
Enhanced PoE Mode	Standard/Legacy/UPoE
Active PoE Device Live Detection	Yes
PoE Power Recycling	Yes, daily or predefined schedule
PoE Schedule	4 schedule profiles
PoE Extended Mode	Yes, max. up to 250 meters
<b>Layer 2 Functions</b>	
Port Mirroring	TX/RX/both Many-to-1 monitor Up to 4 sessions
VLAN	802.1Q tagged VLAN 802.1ad Q-in-Q tunneling (VLAN stacking) Protocol VLAN Private VLAN (Protected port) GVRP Management VLAN Up to 256 VLAN groups, out of 4094 VLAN IDs
Link Aggregation	IEEE 802.3ad LACP and static trunk Supports 8 groups with 8 ports per trunk
Spanning Tree Protocol	IEEE 802.1D Spanning Tree Protocol (STP) IEEE 802.1w Rapid Spanning Tree Protocol (RSTP) IEEE 802.1s Multiple Spanning Tree Protocol (MSTP) STP BPDU Guard, BPDU Filtering and BPDU Forwarding
IGMP Snooping	IPv4 IGMP snooping v2, v3 IGMP querier Up to 256 multicast groups
MLD Snooping	IPv6 MLD snooping v1, v2, up to 256 multicast groups
QoS	8 mapping IDs to 8 level priority queues - Port number - 802.1p priority - DSCP/IP precedence of IPv4/IPv6 packets Traffic classification based, strict priority and WRR Ingress/Egress Rate Limit per port bandwidth control
Ring	Supports ERPS, and complies with ITU-T G.8032 Recovery time < 450ms
<b>Layer 3 Functions</b>	
IP Interfaces	Max. 64 VLAN interfaces
Routing Table	Max. 32 routing entries
Routing Protocols	IPv4/IPv6 hardware static routing

Security Functions	
Access Control List	IPv4/IPv6 IP-based ACL/MAC-based ACL IPv4/IPv6 IP-based ACE/MAC-based ACE Max. 256 ACL entries
Port Security	Built-in RADIUS client to co-operate with RADIUS server RADIUS/TACACS+ user access authentication
MAC Security	IP-MAC port binding MAC filter Static MAC address, max. 256 static MAC entries
Enhanced Security	DHCP Snooping and DHCP Option82 STP BPDU guard, BPDU filtering and BPDU forwarding DoS attack prevention ARP inspection IP source guard
Management Functions	
Basic Management Interfaces	Console Web browser Telnet SNMP v1, v2c
Secure Management Interfaces	SSHv2, TLS v1.2, TLS v1.3, SNMP v3
System Management	Firmware upgrade by HTTP/TFTP protocol through Ethernet network Configuration upload/download through HTTP/TFTP LLDP protocol SNTP PLANET Smart Discovery Utility PLANET NMS/CloudNMS
Event Management	Remote/Local Syslog System log
SNMP MIBs	RFC 1213 MIB-II RFC 1215 Generic Traps RFC 1493 Bridge MIB RFC 2674 Bridge MIB Extensions RFC 2737 Entity MIB (Version 2) RFC 2819 RMON (1, 2, 3, 9) RFC 2863 Interface Group MIB RFC 3635 Ethernet-like MIB RFC 3621 Power Ethernet MIB LLDP MIB PLANET-Aggr-MIB PLANET-DDMI-MIB PLANET-Firmware-MIB PLANET-GVRP-MIB PLANET-LACP-MIB PLANET-SYSUTIL-MIB PLANET-CONFIG-VLANDATA-MIB PLANET-CONFIG-PORTDATA-MIB PLANET-CONFIG-QOSDATA-MIB PLANET-CONFIG-LACPPORTDATA-MIB PLANET-CONFIG-REMOTESYSLOG-MIB PLANET-CONFIG-SNTPDATA-MIB PLANET-CONFIG-UPGRADEDATA-MIB PLANET-CONFIG-BACKUPDATA-MIB PLANET-CONFIG-SYSTEM-MIB_v2 PLANET-CONFIG-LLDPDATA-MIB
Management Functions	
Regulatory Compliance	FCC Part 15 Class A, CE

Standards Compliance	IEEE 802.3 10BASE-T
	IEEE 802.3u 100BASE-TX/100BASE-FX
	IEEE 802.3z Gigabit SX/LX
	IEEE 802.3ab Gigabit 1000BASE-T
	IEEE802.3ae 10Gb/s Ethernet
	IEEE 802.3x Flow Control and Back Pressure
	IEEE 802.3ad Port Trunk with LACP
	IEEE 802.1D Spanning Tree Protocol
	IEEE 802.1w Rapid Spanning Tree Protocol
	IEEE 802.1s Multiple Spanning Tree Protocol
	IEEE 802.1p Class of Service
	IEEE 802.1Q VLAN Tagging
	IEEE 802.1ab LLDP
	IEEE 802.3af Power over Ethernet
	IEEE 802.3at Power over Ethernet Plus
	IEEE 802.3bt Power over Ethernet Plus Plus
	IEEE 802.3az for Energy-Efficient Ethernet
	RFC 768 UDP
RFC 783 TFTP	
RFC 791 IP	
RFC 792 ICMP	
RFC 2068 HTTP	
RFC 1112 IGMP v1	
RFC 2236 IGMP v2	
RFC 3376 IGMP v3	
RFC 2710 MLD v1	
RFC 3810 MLD v2	
ITU-T G.8032 ERPS Ring	
<b>Environment</b>	
Operating Temperature	0 ~ 50 degrees C
Storage Temperature	-10 ~ 60 degrees C
Humidity	5 ~ 95% (non-condensing)

## Dimensions

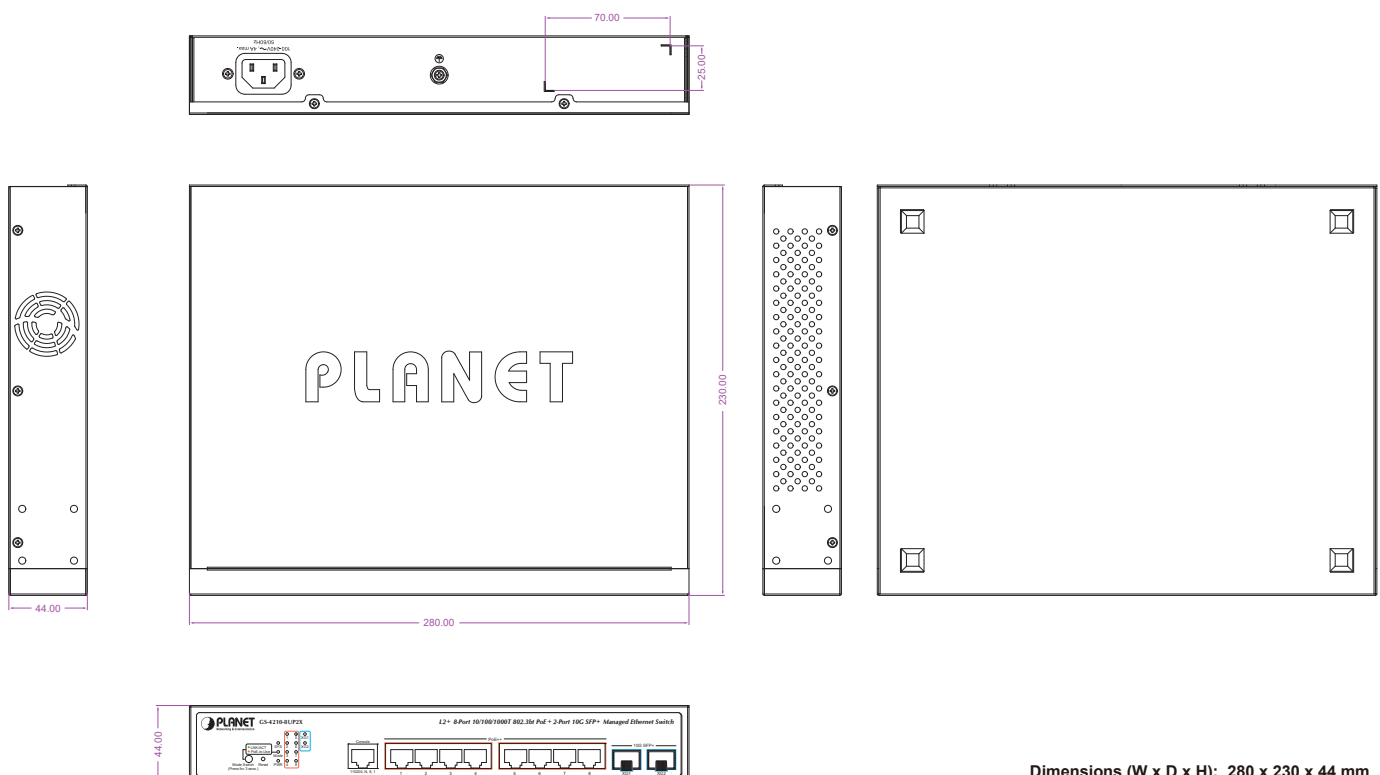

Dimensions (W x D x H): 280 x 230 x 44 mm

## Ordering Information

GS-4210-8UP2X	8-Port 10/100/1000T 802.3bt PoE + 2-Port 10G SFP+ Managed Ethernet Switch
---------------	---

## Related Products

GS-4210-24UP4X	24-Port 10/100/1000T 802.3bt PoE + 4-Port 10G SFP+ Managed Ethernet Switch
GS-4210-16UP8T4X	16-Port 10/100/1000T 802.3bt PoE + 8-Port 10/100/1000T + 4-Port 10G SFP+ Managed Ethernet Switch
MTB-Series Module	10GBASE-LR/SR/BX/T Modules
MGB-Series Transceiver	1000BASE-SX/LX SFP Transceiver
MFB-Series Transceiver	100BASE-FX SFP Transceiver

## Available SFP/SFP+ Modules

### 10 Gigabit Ethernet Transceiver (10GBASE-X SFP+)

MTB-LB40	1-Port 10GBASE-BX SFP+ Fiber Optic Module - 40km (TX:1330nm RX:1270nm)
MTB-LA40	1-Port 10GBASE-BX SFP+ Fiber Optic Module - 40km (TX:1270nm RX:1330nm)
MTB-LB20	1-Port 10GBASE-BX SFP+ Fiber Optic Module - 20km (TX:1330nm RX:1270nm)
MTB-LA20	1-Port 10GBASE-BX SFP+ Fiber Optic Module - 20km (TX:1270nm RX:1330nm)
MTB-SR	1-Port 10GBASE-SR SFP+ Fiber Optic Module - 300m
MTB-LR	1-Port 10GBASE-LR SFP+ Fiber Optic Module - 10km
MTB-LA60	1-Port 10GBASE-BX SFP+ Fiber Optic Module - 60km (TX:1270nm RX:1330nm)
MTB-LB60	1-Port 10GBASE-BX SFP+ Fiber Optic Module - 60km (TX:1330nm RX:1270nm)
MTB-RJ	1-Port 10GBASE-T SFP+ Copper Fiber Optic Module - 30m
MTB-LR40	1-Port 10GBASE-LR SFP+ Fiber Optic Module - 40km
MTB-SR2	1-Port 10GBASE-SR SFP+ Fiber Optic Module - 2km
MTB-LR20	1-Port 10GBASE-LR SFP+ Fiber Optic Module - 20km
MTB-LR60	1-Port 10GBASE-LR SFP+ Fiber Optic Module - 60km
MTB-LR80	1-Port 10GBASE-LR SFP+ Fiber Optic Module - 80km
MTB-LA10	1-Port 10GBASE-BX SFP+ Fiber Optic Module - 10km (TX:1270nm RX:1330nm)
MTB-LB10	1-Port 10GBASE-BX SFP+ Fiber Optic Module - 10km (TX:1330nm RX:1270nm)

### 2.5 Gigabit Ethernet Transceiver (2500GBASE-X SFP)

MGB-2GSR	2.5G SFP Transceiver (Multi-mode, 850nm, DDM, 0~70 degrees C) - 300m
MGB-2GLA20	2.5G SFP Transceiver (Single mode WDM, TX:1310nm RX:1550nm, DDM, 0~70 degrees C) - 20km
MGB-2GLB20	2.5G SFP Transceiver (Single mode WDM, TX:1550nm RX:1310nm, DDM, 0~70 degrees C) - 20km
MGB-2GLR20	2.5G SFP Transceiver (Single mode, 1310nm, DDM) - 20km
MGB-2GLR2	2.5G SFP Transceiver (Single mode, 1310nm, DDM) - 2km

Gigabit Ethernet Transceiver (1000GBASE-X SFP)

MGB-GT	SFP-Port 1000BASE-T Module
MGB-LX	SFP-Port 1000BASE-LX mini-GBIC module - 20km
MGB-SX	SFP-Port 1000BASE-SX mini-GBIC module - 550m
MGB-SX2	SFP-Port 1000BASE-SX mini-GBIC module - 2km
MGB-L40	SFP-Port 1000BASE-LX mini-GBIC module - 40km
MGB-L80	SFP-Port 1000BASE-LX mini-GBIC module - 80km
MGB-L120	SFP-Port 1000BASE-LX mini-GBIC module - 120km
MGB-LA10	SFP-Port 1000BASE-BX (WDM, TX:1310nm) mini-GBIC module - 10km
MGB-LB10	SFP-Port 1000BASE-BX (WDM, TX:1550nm) mini-GBIC module - 10km
MGB-LA20	SFP-Port 1000BASE-BX (WDM, TX:1310nm) mini-GBIC module - 20km
MGB-LB20	SFP-Port 1000BASE-BX (WDM, TX:1550nm) mini-GBIC module - 20km
MGB-LA40	SFP-Port 1000BASE-BX (WDM, TX:1310nm) mini-GBIC module - 40km
MGB-LB40	SFP-Port 1000BASE-BX (WDM, TX:1550nm) mini-GBIC module - 40km
MGB-LA80	SFP-Port 1000BASE-BX (WDM, TX:1490nm) mini-GBIC module - 80km
MGB-LB80	SFP-Port 1000BASE-BX (WDM, TX:1550nm) mini-GBIC module - 80km
MGB-GT	SFP-Port 1000BASE-T Module
MGB-LX	SFP-Port 1000BASE-LX mini-GBIC module - 20km
MGB-SX	SFP-Port 1000BASE-SX mini-GBIC module - 550m
MGB-SX2	SFP-Port 1000BASE-SX mini-GBIC module - 2km
MGB-L40	SFP-Port 1000BASE-LX mini-GBIC module - 40km
MGB-L80	SFP-Port 1000BASE-LX mini-GBIC module - 80km
MGB-L120	SFP-Port 1000BASE-LX mini-GBIC module - 120km
MGB-LA10	SFP-Port 1000BASE-BX (WDM, TX:1310nm) mini-GBIC module - 10km
MGB-LB10	SFP-Port 1000BASE-BX (WDM, TX:1550nm) mini-GBIC module - 10km
MGB-LA20	SFP-Port 1000BASE-BX (WDM, TX:1310nm) mini-GBIC module - 20km
MGB-LB20	SFP-Port 1000BASE-BX (WDM, TX:1550nm) mini-GBIC module - 40km
MGB-LA40	SFP-Port 1000BASE-BX (WDM, TX:1310nm) mini-GBIC module - 40km
MGB-LB40	SFP-Port 1000BASE-BX (WDM, TX:1550nm) mini-GBIC module - 40km
MGB-LA80	SFP-Port 1000BASE-BX (WDM, TX:1490nm) mini-GBIC module - 80km
MGB-LB80	SFP-Port 1000BASE-BX (WDM, TX:1550nm) mini-GBIC module - 80km

Fast Ethernet Transceiver (100BASE-X SFP)

MFB-FX	SFP-Port 100BASE-FX Transceiver (1310nm) -2km
MFB-F20	SFP-Port 100BASE-FX Transceiver (1310nm) - 20km
MFB-FA20	SFP-Port 100BASE-BX Transceiver (WDM,TX:1310nm) -20km
MFB-FB20	SFP-Port 100BASE-BX Transceiver (WDM,TX:1550nm) -20km
MFB-F40	SFP-Port 100BASE-FX Transceiver (1310nm) - 40KM
MFB-F60	SFP-Port 100BASE-FX Transceiver (1310nm) - 60KM
MFB-F120	SFP-Port 100BASE -FX Transceiver (1550nm) - 120km